

ALTEC LANSING ENGINEERING NOTES

TECHNICAL LETTER NO. 183

COMMENTS ON DIRECTIVITY OF LOUDSPEAKERS AND MICROPHONES

By
Don Davis©

Loudspeaker directivity is expressed in two ways; first as the directivity index (D_I) and second as a directivity factor (Q). The D_I is the SPL in dB of a 100% efficient loudspeaker at a given angle of radiation minus the SPL in dB of the same loudspeaker for a perfectly spherical radiation pattern at the same distance. These two parameters can be expressed by the following equations:

$$(eq 1) \quad D_I = 10 \log_{10} Q$$

$$(eq 2) \quad Q = \text{antilog}_{10} \frac{D_I}{10}$$

The formula for finding critical distance (D_c) can also be expressed with this directivity factor Q :

$$(eq 3) \quad D_c = 0.14 \sqrt{QR}$$

The Q of a loudspeaker is therefore the parameter of most use in Acousta-Voicing® work.

The Q of a directional array can be found when the true horizontal and vertical angles of coverage are known. Mr. Andrew Hannon of Hannon Engineering, Los Angeles, California, has devised a very-easy-to-use formula for deriving Q from the coverage angles:

$$(eq 4) \quad Q = \frac{360}{\theta \sin \frac{\phi}{2}}$$

Where θ is the horizontal angle
 ϕ is the vertical angle

Unfortunately, real loudspeakers do not behave this predictably. Figure 1 shows the results of some really marvelous basic work back in 1947 by two members of the Bell Telephone Laboratories, H. F. Hopkins and N. R. Stryker, and published as a paper (pp 315-335) in the Proceedings of the Institute of Radio Engineers in March, 1948. Entitled "A Proposed Loudness Efficiency Rating for Loudspeakers and the Determination of System Power Requirements for Enclosures", this paper contained an appendix, starting on page 329, captioned "Derivation of Loudness-Directivity Index."

In studying this paper, it quickly becomes evident that the D_I and Q ratings for the sound sources shown in Table I can be assumed.

Table I. D_I and Q Rating for Typical Sound Sources

Type of Sound Source	D_I	Q
Person talking (no sound system)	3 dB	2
Coaxial loudspeaker in infinite baffle	7 dB	5
Cone woofers	7 dB	5
Multicellular horns	7-12 dB	5-15
Sectoral horns	7-9 dB	5-9.5

Several of the charts in Figure 1 illustrate the Q of combined arrays in the crossover region that consist of sectoral horns and cone woofers and some show the Q for arrays consisting of multicellular horns and cone woofers.

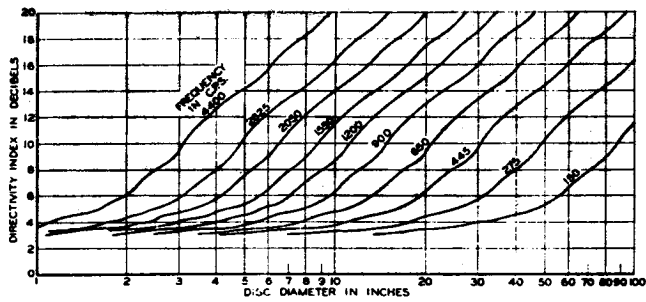

Directivity indexes of rigid disks of various diameters in an infinite baffle at each of the midfrequencies of the ten equal-loudness bands.

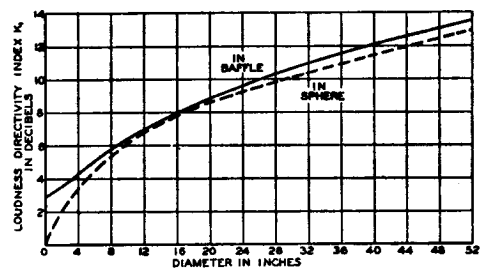

Loudness-directivity index for radiation from a rigid disk in a sphere and in an infinite baffle (circular horn or direct radiator, baffled or unbaffled).

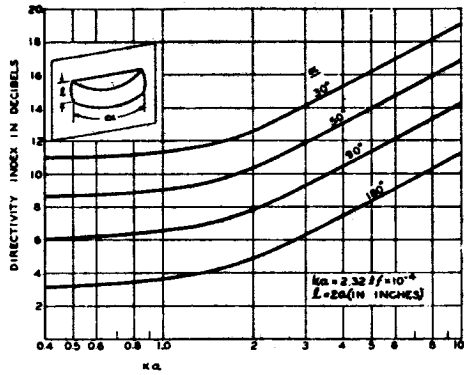

Directivity index for sectoral radiation in an infinite baffle.

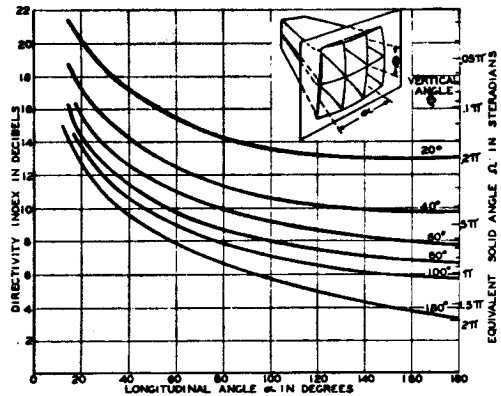

Directivity index from a portion of a spherical zone in an infinite baffle.

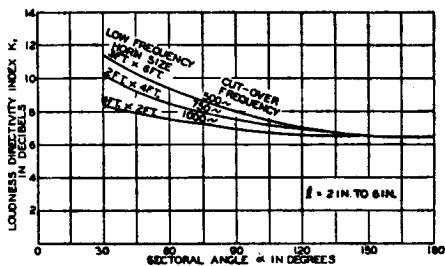

Loudness-directivity index for a dual system involving sectoral radiation and radiation from a rigid rectangular plate in an infinite baffle (rectangular low-frequency horn and sectoral high-frequency horn, baffled).

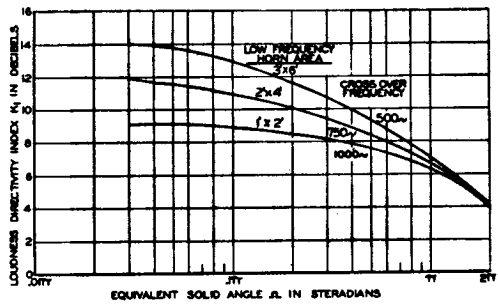

Loudness-directivity index for a dual system involving radiation from a rigid rectangular plate and a portion of a spherical zone in an infinite baffle (rectangular low-frequency horn and a multicellular high-frequency horn, baffled).

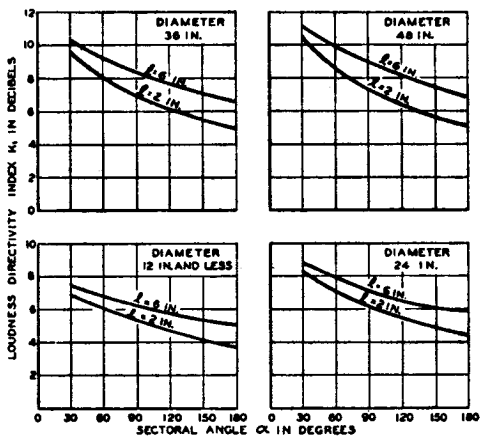

Loudness-directivity index for a dual system involving sectoral radiation and radiation from a rigid disk in an infinite baffle (circular low-frequency direct radiator and sectoral high-frequency horn, baffled).

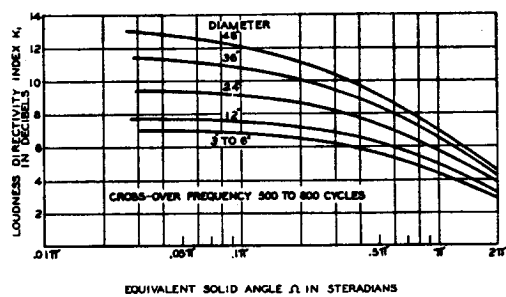

Loudness-directivity index for a dual system involving radiation from a rigid disk and a portion of a spherical zone in an infinite baffle (circular low-frequency direct radiator and a multicellular high-frequency horn, baffled).

Figure 1. Loudness-Directivity Indexes for Various Sound Systems

It is possible to verify the Q of a loudspeaker array in the field by applying the following procedure:

1. Calculate the total surface area (S) in ft².
2. Calculate the total volume (V) in ft³.
3. Measure the RT₆₀ for a band of noise from 200 to 5000 Hz.
4. Calculate $\bar{\alpha}$ in accordance with equation 5.
5. Measure actual D_c.
6. Calculate Q in accordance with equation 6.

$$(eq 5) \quad \bar{\alpha} = 1 - e^{-\left[\frac{0.05V}{S(RT_{60})}\right]}$$

Where e is the natural log base 2.71828, and

$$(eq 6) \quad Q = \frac{D_c^2}{0.0196 S \bar{\alpha}}$$

When evaluating a new arrangement of loudspeakers in an array, it is advisable to measure the Q of the array as a whole.

Figure 2 shows the correct way to arrange a loudspeaker array to increase horizontal distribution. If the arrangement of Figure 3 is used, the frequency response off axis can double its irregularities as compared to frequency response measurements obtained on axis. In the future, for even greater accuracy in the use of D_c as a limit on D₁, D_s, D_o and D₂, it would be best to first calculate D_c with a Q of 2 for unamplified talker's D_o and then calculate D_c with a Q of 5 for use in sound system analysis. Use Table II and Figure 4 in conjunction with equations 1, 2, 4, 6 and 7 to calculate these Q factors with ease.

$$(eq 7) \quad 107.40 \text{ dB} = \text{SPL generated by a 100\% efficient loudspeaker at 4 feet over a spherical surface area from 1 watt input}$$

Table II. SPL in dB at 4 Feet from 1 Watt for a 100% Efficient Loudspeaker Radiating into Various Angles

Angle	dB-SPL	D _I	Q
360°	107.40	0 dB	1.00
180°	110.41	3.01 dB	2.00
160°	111.24	3.84 dB	2.42
120°	113.42	6.02 dB	4.00
106°	114.41	7.01 dB	5.00
90°	115.74	8.34 dB	6.82
60°	119.14	11.74 dB	14.92
45°	121.59	14.19 dB	26.26
30°	125.08	17.68 dB	58.66
15°	131.09	23.69 dB	233.65
10°	134.60	27.20 dB	525.30
5°	140.62	33.22 dB	2100.21
1°	154.60	47.20 dB	52,497.21

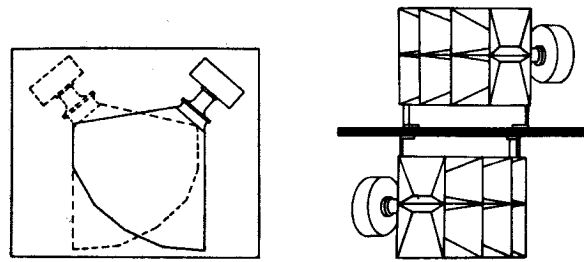

Figure 2. Proper Method for Increasing Horizontal Distribution of a Loudspeaker Array

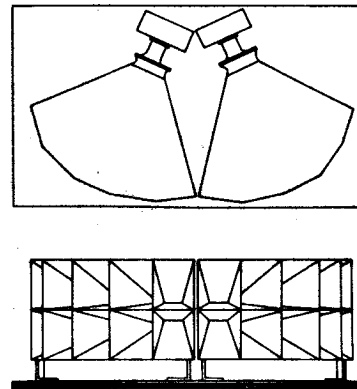

Figure 3. Improper Method for Increasing Horizontal Distribution of a Loudspeaker Array

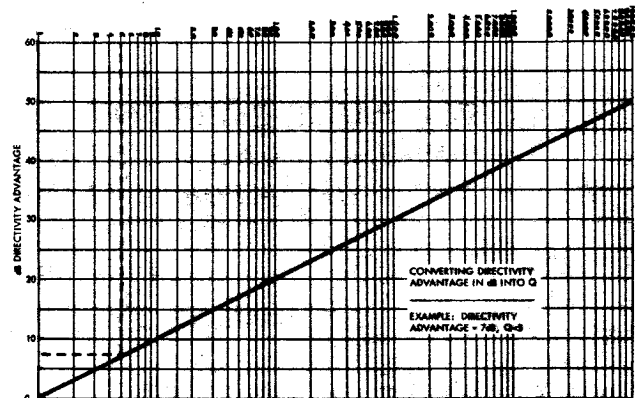

Figure 4. Converting Directivity Advantage in dB into Q

MEASURING MICROPHONE DIRECTIVITY EFFECTS

The size of the microphone used to make an acoustic measurement can cause an appreciable effect at frequencies above 5000 Hz. Figures 5 and 6 show the change in response of 1" and 1/2" condenser microphones when used in free field and in diffuse or reverberant field measurements.

To determine whether to use the 0° incidence curves given in Letter CE 29 or the random incidence curve, you must know if you are in the direct or reverberant sound field. The best test for this is to place a 1/3-octave band of noise centered at 10,000 Hz on the loudspeaker and take a reading with the sound level meter at 0° incidence (the microphone of the sound level

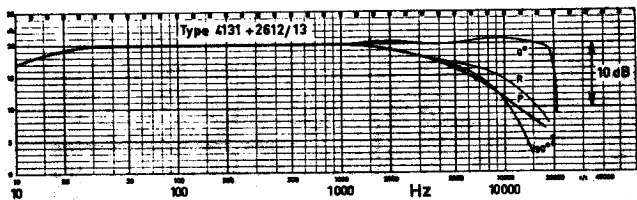

Figure 5. Effect of Microphone Directivity on Sensitivity with 1-Inch Microphone

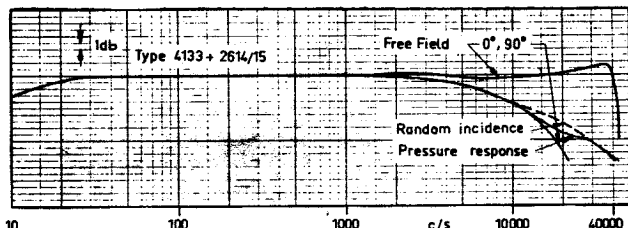

Figure 6. Effect of Microphone Directivity on Sensitivity with 1/2-Inch Microphone

meter pointed at the loudspeaker array) and then take a 90° incidence reading (the microphone of the sound level meter pointed at a right angle to the loudspeaker array). If the readings are different, assume you are in the direct sound field and use 0° incidence readings. If the readings are not different, you may safely assume you are in the reverberant sound field. The high-frequency rolloff due to random incidence must therefore be added to whatever rolloff is required due to air absorption.

CONCLUSION

These figures, tables and equations can serve as accurate guides in the realistic assessment of the directional assistance to be expected from varying types of loudspeaker arrays.

THE PAPER REPRINTED BELOW IS EXCEPTIONAL FOR ITS CONCISE, FUNDAMENTAL APPROACH TO THE MEASUREMENT OF IMPORTANT SOUND SYSTEM PARAMETERS.

*Reprinted from The March 1948 Edition of
The Proceedings of The I. R. E.*

A Proposed Loudness-Efficiency Rating for Loudspeakers and the Determination of System Power Requirements for Enclosures*

H. F. HOPKINS† AND N. R. STRYKER†

Summary—Experimental and computed data relating to the loudness contribution of various ranges of the frequency spectra of speech and music are correlated with the corresponding energy distribution. A relatively simple measurement of sound pressure and a knowledge of certain acoustic radiation phenomena are applied to this correlation to form the basis of a method for predicting the loudness established by loudspeakers in enclosures. A loudness-efficiency rating for loudspeakers is suggested, and its application to sound-system engineering problems is described.

* Decimal classification: R265.2. Original manuscript received by the Institute, May 11, 1947; revised manuscript received, September 19, 1947. Presented, Chicago Convention, Society of Motion Picture Engineers, Chicago, Ill., April 21–25, 1947.

† Bell Telephone Laboratories, Inc., Murray Hill Laboratory, Murray Hill, N. J.

INTRODUCTION

FOR SOME TIME those associated with the industrial application of acoustics have expressed the need for a loudspeaker rating directly related to the loudness that the instrument can produce under specified acoustic conditions. Assuming that the suitability of a loudspeaker for its intended use has been determined on the basis of a full appraisal of its various attributes, this paper is confined to the problem of defining its loudness, discussing in detail a study of factors involved in establishing a practical loudness rating, and presenting a method for applying it.

Certain factors based on the theory of loudness^{1,2} are used in developing the relationships involved in this study. Loudness is a subjective function, and requires considerable experimental data before it can be quantitatively expressed. Such data have been compiled, although not all are available in published form. Sound intensity, on the other hand, is very generally understood, and is commonly obtained from a measurement of sound pressure. The relationship of loudness and intensity is complex, but is readily derived using physical factors which have been determined experimentally. Since the energy spectrum of the reproduced sound must be known in determining the loudness contribution of specified frequency bands, the present discussion will be limited to speech and music, for which such data are available. These are, of course, the most commonly reproduced sound spectra.

The conclusion is that a relatively simple measurement of sound pressure can be used to determine the loudness efficiency of a loudspeaker. This measurement must be related to the total acoustic output of the instrument, and, therefore, the directivity must be determined. The loudness-efficiency factor thus obtained can be used to determine the loudness per available electrical watt in any enclosure for which the acoustic constants are known. Sound levels, necessary for adequate reproduction of speech and music, are established, and the power requirements for any specified enclosure are readily determined. Certain simplifications have been introduced in the interests of practicability.

DETERMINATION OF LOUDNESS-EFFICIENCY RATING

Theory

The intensity-versus-frequency distribution in average speech for men and women has been published by French and Steinberg.³ The data are shown in curve A, Fig. 1, in the form of the intensity per cycle throughout the frequency range for a maximum r.m.s. intensity level of 78 db over 0.25-second intervals. This is a representative level⁴ existing at a distance of 2.5 feet from the lips of a person talking conversationally. Curves B and C indicate the intensity-versus-frequency distribution for music played by a 15- to 18-piece and by 75-piece orchestras at intensity levels of 96 and 106 db, respectively.^{5,6} These levels⁷ are representative and exist at a distance of 30 feet from the source. As shown

later, the sound meter and volume indicator, which integrate over 0.25-second intervals, will indicate levels 10 db below those given above, when used to indicate

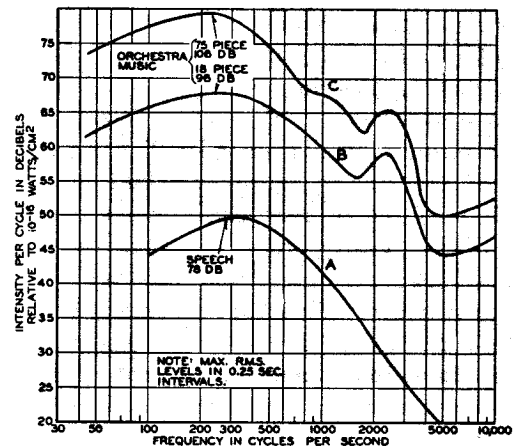

Fig. 1—Intensity-versus-frequency distribution for speech and music.

long r.m.s. intensity levels over intervals much greater than 0.25 second. On Fig. 2 the data for speech and

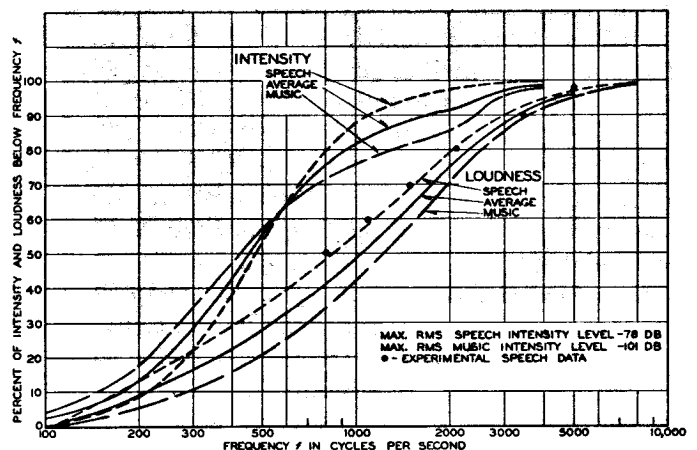

Fig. 2—Percentage of intensity and loudness below any frequency in the spectrum for speech or music.

music are replotted in terms of the percentage of intensity in the frequency band below each frequency of the abscissa. An average curve which is assumed to be sufficiently representative for either speech or music is also shown. The data for speech are more comprehensive than those for music, but, because of the similarity of the two spectra, it is believed that the average should provide a good compromise on which to base an over-all loudness rating.

Experimental speech data from unpublished work of W. A. Munson and given very briefly by Fletcher⁶ are shown by the dots on Fig. 2 in terms of the percentage of loudness in the frequency band below each frequency

¹ H. Fletcher and W. A. Munson, "Relation between loudness and masking," *Jour. Acous. Soc. Amer.*, vol. 9, pp. 1-10; July, 1937.

² H. Fletcher and W. A. Munson, "Loudness, its definition, measurement, and calculation," *Jour. Acous. Soc. Amer.*, vol. 5, pp. 82-108; October, 1933.

³ N. R. French and J. C. Steinberg, "Factors governing the intelligibility of speech," presented May, 1945. *Jour. Acous. Soc. Amer.*, vol. 19, pp. 90-120; January, 1947.

⁴ 76 db at a distance of 1 meter.

⁵ L. J. Sivian, H. K. Dunn, and S. D. White, "Absolute amplitudes and spectra of certain musical instruments and orchestras," *Jour. Acous. Soc. Amer.*, vol. 2, pp. 330-371; January, 1931.

⁶ H. Fletcher, "Hearing, the determining factor for high-fidelity mission," *PROC. I.R.E.*, vol. 30, pp. 266-277; June, 1942.

⁷ 104 and 94 db at a distance of 10 meters.

of the abscissa. Employing curve A of Fig. 1 and the methods outlined by Fletcher and Munson,¹ loudness computations for speech were made. The results are plotted on Fig. 2. The computed and experimental data for speech agree quite closely. Therefore, it may be assumed with reasonable confidence that the same method of calculating loudness may be applied to other sound spectra such as those indicated for music. Applying this method to curves B and C of Fig. 1, an average curve for music is shown on Fig. 2. A representative average of the curves for speech and music is also shown. It is observed that the average curve for intensity differs greatly from that for loudness. The loudness-versus-frequency distribution will vary somewhat with intensity. Between intensity levels of 90 to 110 db for music and 70 to 90 db for speech, however, the maximum variation is only 2 per cent. The intensity levels employed in this analysis are 78 db for speech and 101 db for music.

If the relationship between loudness and intensity for these typical high-level sound spectra can be established, a simple acoustic measurement involving the intensity may be made indicative of the loudness. The intensity of any part of a sound spectrum is equal to the product of the frequency bandwidth and the average intensity per cycle within that band. Thus, for a flat sound spectrum, equal frequency increments would contribute equal proportions of the total intensity. The loudness contributions for the various frequency increments, as indicated on Fig. 2, however, differ materially from the intensity contributions in the same frequency increments. Therefore, an intensity measurement will be proportional to loudness only if the intensity contributions of the frequency bands are properly weighted.

Complicated relationships between sound intensity and loudness exist for complex, intermittent sounds such as those involved in speech and music. Since we are here concerned with a limited range of sound levels and loudspeakers having relatively uniform response, some simplification can be attained by neglecting certain factors in the general loudness theory. This leads to the conclusion that, within certain limits, a sufficient approximation of loudness may be determined from a loudness-versus-intensity relationship involving only frequency weighting. This relationship may be derived from the curves of Fig. 2, establishing a frequency-weighting factor which, when applied to a sweep-frequency band, reduces equal sweep-time intervals to equal proportions of the total loudness. Applying this sweep-frequency band to a loudspeaker, a single measurement of the resulting sound pressure can be used as a measure of loudness for the intensity-level ranges specified above. Experimental verification of this procedure is presented later.

A frequency band having a range of 100 to 6000 cycles includes 96 per cent of the loudness spectrum. Ten frequency bands in this range which contribute

equal loudness increments may be selected, as shown on the abscissa of Fig. 3, with midfrequencies as indi-

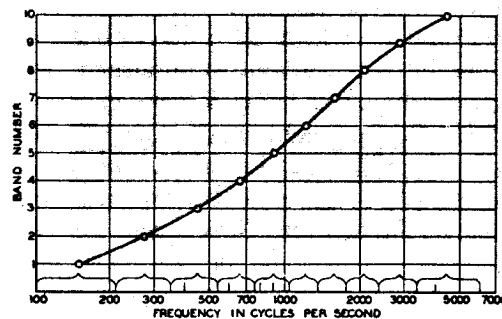

Fig. 3—Midfrequencies of ten equal loudness bands.

cated on the curve. The data from this curve may be utilized to establish the time rate of frequency change for a weighted sweep-frequency band, since the frequency sweep in each of these ten loudness increments should occur during an equal time interval. This relationship is shown by the curve of Fig. 4, the slope of

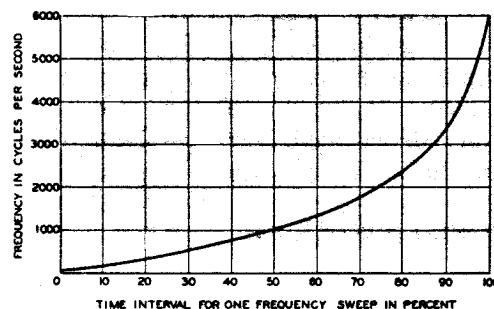

Fig. 4—Frequency-versus-time modulation for loudness weighting.

which indicates the rate of frequency change in a sweep-frequency band which, when applied to a loudspeaker, will permit a pressure measurement to be made that is representative of loudness. This measurement of pressure must be related to the total acoustic output of the loudspeaker.

The total acoustic power radiated from a loudspeaker is a function of the size and shape of the radiating area as well as of the frequency. If the radiating area is a point source the total power is easily derived, because the spatial energy distribution is uniform throughout a solid angle of 4π steradians. As the size of the radiating area of the practical loudspeaker is increased, it becomes more directional. Other investigators⁸⁻¹¹ have derived

⁸ Lord Rayleigh, "Theory of Sound," Macmillan Publishing Co., New York, N. Y., vol. II, 1896.

⁹ H. O. Stenzel, *Elec. Nach. Tech.*, vol. 6, pp. 165-181; August, 1927.

¹⁰ H. O. Stenzel, *Elec. Nach. Tech.*, vol. 4, pp. 239-253; June, 1927.

¹¹ I. Wolff and L. Malter, "Directional radiation of sound," *Jour. Acous. Soc. Amer.*, vol. 2, pp. 201-241; October, 1930.

the means for the determination of the total power radiation from a line or a rigid disk radiator located in an infinite baffle. Since all types of loudspeakers are not located in an infinite baffle, the total power radiation must be obtained for other boundary conformations. For a given electrical input, the axial pressure is a function of the efficiency of the loudspeaker as well as of its boundary conformation. Consequently, pressure measurements on the ax axis of a loudspeaker are indicative of the total acoustic power radiated only if a proper correction factor for the directivity of the device can be determined.

Considering these facts, let us assume first that the loudspeaker is a point source of sound located in free space. An electrical power W_e is supplied over the loudness-weighted sweep-frequency range of 100 to 6000 cycles. The rate of frequency change is assumed to be in accordance with the slope of the characteristic of Fig. 4. The axial sound pressure p_{ax} , in dynes per square centimeter, as indicated by a thermal meter, is determined at a distance of 30 feet from the source. The reason for choosing a test distance of 30 feet will be made evident later.

The sound intensity in watts/cm.², for an electrical power of W_e watts, is

$$I_{ax} = \frac{p_{ax}^2}{\rho c} \times 10^{-7}. \quad (1)$$

The intensity level in db relative to reference intensity (10^{-16} watts/cm.²) is

$$L_{I_{ax}} = 10 \log I_{ax} + 160 \quad (2)$$

or the pressure level in decibels

$$L_{p_{ax}} = 20 \log p_{ax} + 74. \quad (3)$$

Then the total loudness-weighted acoustic power radiated, in watts, is

$$W_L = S_e \times I_{ax} \quad (4)$$

or, if the pressure p_{ax} is used,

$$W_L = \frac{S_e p_{ax}^2}{\rho c} \times 10^{-7} \text{ watts} \quad (5)$$

in which

S_e = surface of a sphere in cm.² having a radius of 30 feet.

= 10.5×10^6 cm.² or 70.2 db relative to 1 cm.²

ρc = characteristic plane-wave impedance of air in mechanical ohms/cm.². If a reference pressure p_c of 0.0002 dynes per square centimeter is assumed at a reference intensity I_0 of 10^{-16} watts/cm.², a value of 40 mechanical ohms per square centimeter follows for ρc . ρc does not actually attain this value for typical atmospheric conditions, but the error due to this assumption is only a few tenths of a decibel.

Defining W_{ec} as the power capacity¹² of the loudspeaker in watts, the total loudness-weighted acoustic power per available electrical watt input is

$$W_{L_e} = \frac{S_e I_{ax}}{W_{ec}}. \quad (6)$$

Then L_e , the loudness-weighted acoustic power level in db relative to 1 acoustic watt per available electrical watt, is

$$\begin{aligned} L_e &= 10 \log_{10} W_{L_e} = 10 \log_{10} \frac{S_e I_{ax}}{W_{ec}} \\ &= L_{I_{ax}} - 160 + 70.2 - k \\ &= L_{I_{ax}} - 89.8 - k \end{aligned} \quad (7)$$

where $k = 10 \log_{10} W_{ec}$.

In terms of the pressure p_{ax} ,

$$L_e = 20 \log_{10} p_{ax} - 15.8 - k. \quad (8)$$

Equations (7) and (8) apply to a point source, which is a convenient reference because maximum power is radiated throughout the entire frequency range for a given axial intensity. The acoustic power radiated from a loudspeaker, which is a source of finite size, can be expressed in terms of its ratio to that radiated from a point source. This ratio, K_1 expressed in db, may be termed the loudness-directivity index, and can be applied as a correction factor in (7) or (8). Since loudness-weighted sweep-frequency power has been assumed in determining the effective pressure, either of these equations may be used to derive a loudness rating for loudspeakers. Thus L_e , the intensity level in db relative to 1 acoustic watt per available electrical watt, is

$$L_e = L_{ax} - 89.8 - k - K_1, \quad (9)$$

¹² Considerable thought has been given to an appropriate rating for electrical power input to a loudspeaker. Recently the available-power method has been gaining wide acceptance because of certain simplifications in measurement which result from its use. By this method, the power is defined as that delivered to a resistance R equal to the rating impedance of the loudspeaker from a source of constant voltage E in series with a resistance also equal to the rating impedance. The power available is then $E^2/4R$, and when power to the loudspeaker is referred to, this quantity is meant.

The power capacity of a loudspeaker is then the maximum available power at which satisfactory operation of the instrument may be obtained. Depending upon the type of loudspeaker, the power capacity may be limited, due to distortion or mechanical breakage. Tolerable distortion may be determined by listening tests or measurements, and the value will depend on the requirements involved in the specific type of application. There appears to be no standardized procedure for determining the safe operating point from the standpoint of mechanical failure. At Bell Telephone Laboratories, we have been testing in a manner which appears to insure mechanical stability but which may result in a conservative rating as compared to other methods. For direct-radiator devices, a uniform sweep-frequency band from 50 to 1000 cycles is applied to the loudspeaker set up in the recommended operating condition. The power capacity of the loudspeaker is then considered to be the maximum available power at which no failures occur in a continuous testing period of 100 hours. No ambient temperature is specified except where special applications are involved. For horn-driver units, a sweep frequency 2000 cycles wide whose lowest frequency is 100 cycles below the lowest resonant frequency of the loudspeaker is used. This assumes that the unit is equipped with a recommended horn. Since no standardized method for determining the power capacity of loudspeakers exists at the present time, W_{ec} may be considered to be the manufacturer's rating of his product.

or the total loudness-weighted acoustic power per available electrical watt is

$$W_{L_e} = 10i_0 \cdot \frac{L_e}{10} \quad (10)$$

The term loudness-efficiency factor LR has been selected as a suitable expression for rating the loudness of a loudspeaker. Thus,

$$LR = 100W_{L_e} \text{ in per cent.} \quad (11)$$

This factor provides an expression for the loudness efficiency of a loudspeaker which may be obtained from a simple measurement of the axial sound pressure in a free field for a weighted sweep-frequency power supply, and is suitable for determining the amplifier power and the number of loudspeakers required for a specified sound-system installation.

The correction factor K_1 used in (9) has been termed the loudness-directivity index, and may be defined as the ratio, expressed in decibels, of the total loudness-weighted power radiated by a loudspeaker to that radiated by a point source producing the same axial pressure. It is possible to compute the total acoustic power from most radiating devices at any specific frequency. The ratio of this power to that radiated by a point source producing the same axial pressure, expressed in decibels, may be defined as the directivity index. Since the directivity index of a loudspeaker is a function of the shape of the radiating area and its boundary conditions, as well as of the frequency, these factors must be taken into account in determining the loudness-directivity index. If the directivity index of a given radiating device be computed for each of the ten midfrequencies of the equal loudness bands shown on Fig. 3, the loudness-directivity index may be computed as shown by (53) in the Appendix.

Although loudspeakers exist in a wide variety of shapes, the radiating areas, in general, are simple geometric forms, either baffled or unbaffled, most of which lend themselves to theoretical analysis. Various types of loudspeakers used in practice are described in the Appendix, and derivations of their loudness-directivity indexes are given.

Determination of Test Sweep-Frequency Power

The test-frequency range of 100 to 6000 cycles, which includes 96 per cent of the loudness range, was used for accuracy in computing the loudness-directivity index K_1 . In order to attain simplicity in the measuring equipment, a modification in the width of the test sweep-frequency band can be made without materially affecting the results. Fig. 2 indicates that 75 per cent of the loudness as well as the intensity of speech and music occurs between 300 and 3300 cycles (only 1.3 db less than the total). A sweep-frequency band of this width would appear to provide a range adequate for a pressure measurement indicating loudness. The frequency-versus-

time relation providing a loudness-weighted sweep band is indicated by the "NORMAL" curve of Fig. 5. The

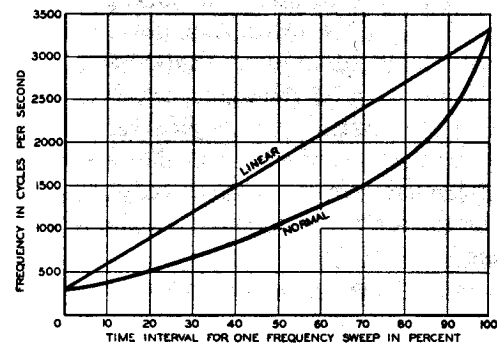

Fig. 5—Frequency-versus-time relations of 300- to 3300-cycle sweep band.

rate of frequency change is not linear and would require a specially shaped capacitor plate in a frequency-modulated generator. It appears desirable from a practical standpoint to make this frequency variation linear throughout the range, as indicated by the "LINEAR" curve of Fig. 5. A linear frequency sweep can be made to produce the same pressure or intensity level as the "NORMAL" frequency sweep if the proper corrective electrical network is inserted in the output circuit of the generator. Equalization for this purpose was computed using the average curve of loudness for speech and music shown on Fig. 2. The computed curve as well as the frequency characteristic of a suitable equalizer providing a close approximation are shown on Fig. 6.

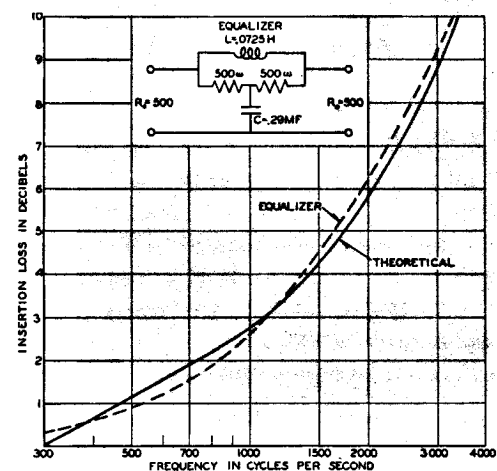

Fig. 6—Loudness-weighting equalization for a linear frequency-versus-time sweep band.

A schematic of this equalizer is also shown on the figure. A possible alternative source of power might be a flat noise spectrum equalized in this manner.

A sweep-frequency band is a frequency-modulated signal in which discrete frequency components result throughout the entire bandwidth, as pointed out by

other investigators.¹³⁻¹⁵ The amplitude and the number of components are dependent on the modulation index, which is a function of bandwidth and the rate at which the carrier is modulated. The form of the envelope of the components is of great importance in this problem. The most uniform amplitude envelope and the maximum number of components occur for a linear frequency-versus-time relation having a unidirectional frequency sweep, a sawtooth envelope, and a high modulation index. A reciprocating frequency sweep such as that shown on Fig. 7(a), with a sweep rate of 6 per second, produces 500 components having an envelope of the

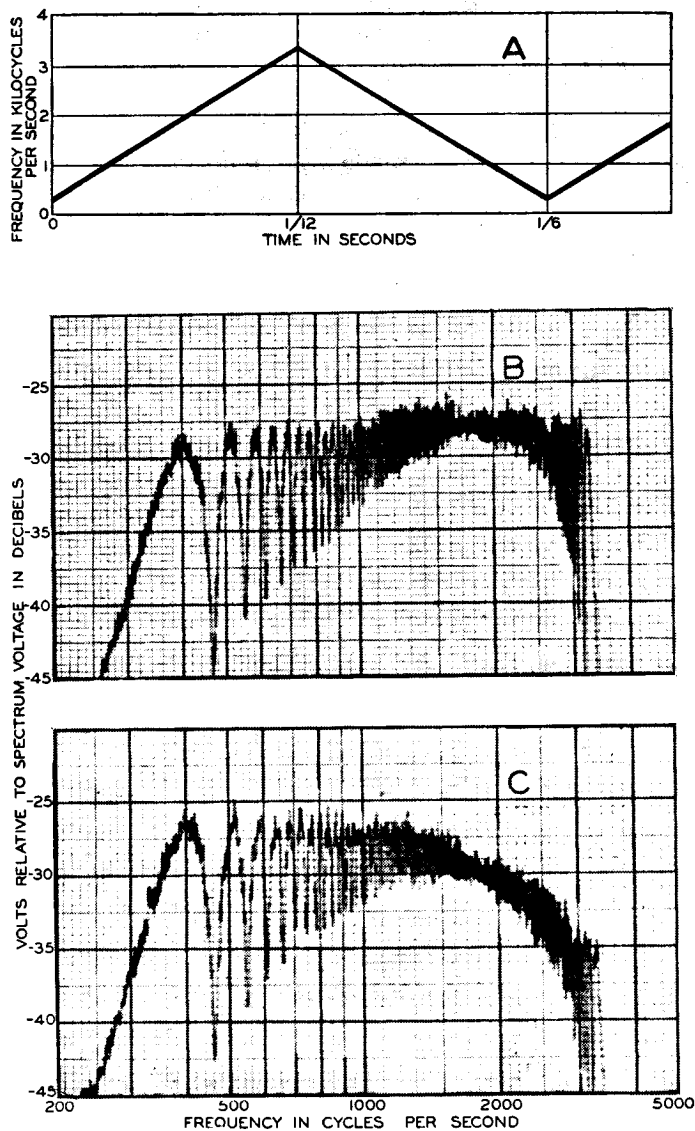

Fig. 7—(a) Frequency-versus-time relation for a linear reciprocating sweep, (b) Envelope of the components of the sweep band of (a). (c) Envelope of the components of the sweep band of (a) with loudness-weighting equalization.

¹³ J. R. Carson, "Notes on the theory of modulation," *PROC. I.R.E.*, vol. 10, pp. 57-66; February, 1922.

¹⁴ Balth van der Pol, "Frequency modulation," *PROC. I.R.E.*, vol. 18, pp. 1194-1205; July, 1930.

¹⁵ W. R. Bennett, unpublished memorandum, Bell Telephone Laboratories, Inc.

form shown on Fig. 7(b). With the equalizer in circuit, the envelope is modified as shown by Fig. 7(c).

Experimental

In order to justify the validity of this method, the loudness rating of a series of loudspeakers representing a wide range of response-versus-frequency characteristics was determined experimentally. The loudness of these loudspeakers relative to that of a reference condition as judged by a number of observers was also determined for comparison with the measured loudness ratings.

A Western Electric 728-B loudspeaker was used as a reference instrument. The loudspeaker system shown on Fig. 8, in which various test conditions could be ob-

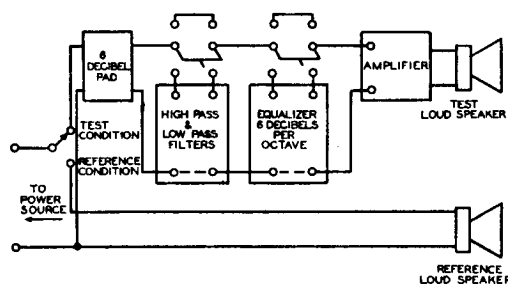

Fig. 8—Test circuit for loudness observations.

tained by the use of networks, was used for these tests. The networks employed consisted of low- and high-pass filters and a network producing a 6-db-per-octave rise in the response of the test loudspeaker. This loudspeaker system consisted of a 6-db pad, the networks, a variable-gain amplifier, and a 728-B loudspeaker having practically the same response-versus-frequency characteristic as that of the reference unit. The system was considered as an individual loudspeaker for each circuit condition. The gain settings of the amplifier were different for each condition, to provide a range of efficiencies. A D-173181 Western Electric loudspeaker, developed to provide high intelligibility under noisy conditions, was included as an additional test unit.

Response-versus-frequency characteristics for the reference condition and for each of the test conditions were made in a dead room at a distance of 3 feet from and on the speaker axis, and are shown on Fig. 9. The power supply and the sensitivity of the measuring circuit were held constant in each case. These data permit a determination of the efficiency in the passed band for each condition relative to that for the reference condition.

Using a source of sweep-frequency power having the characteristics shown on Fig. 7(b) and 7(c), the axial pressure p_{ax} , 3 feet from each speaker, was measured in the dead room for a range of input power, all measurements being made with thermal meters. Over the range of power employed, a linear pressure-versus-power relation existed and, therefore, the effective pressure for 1

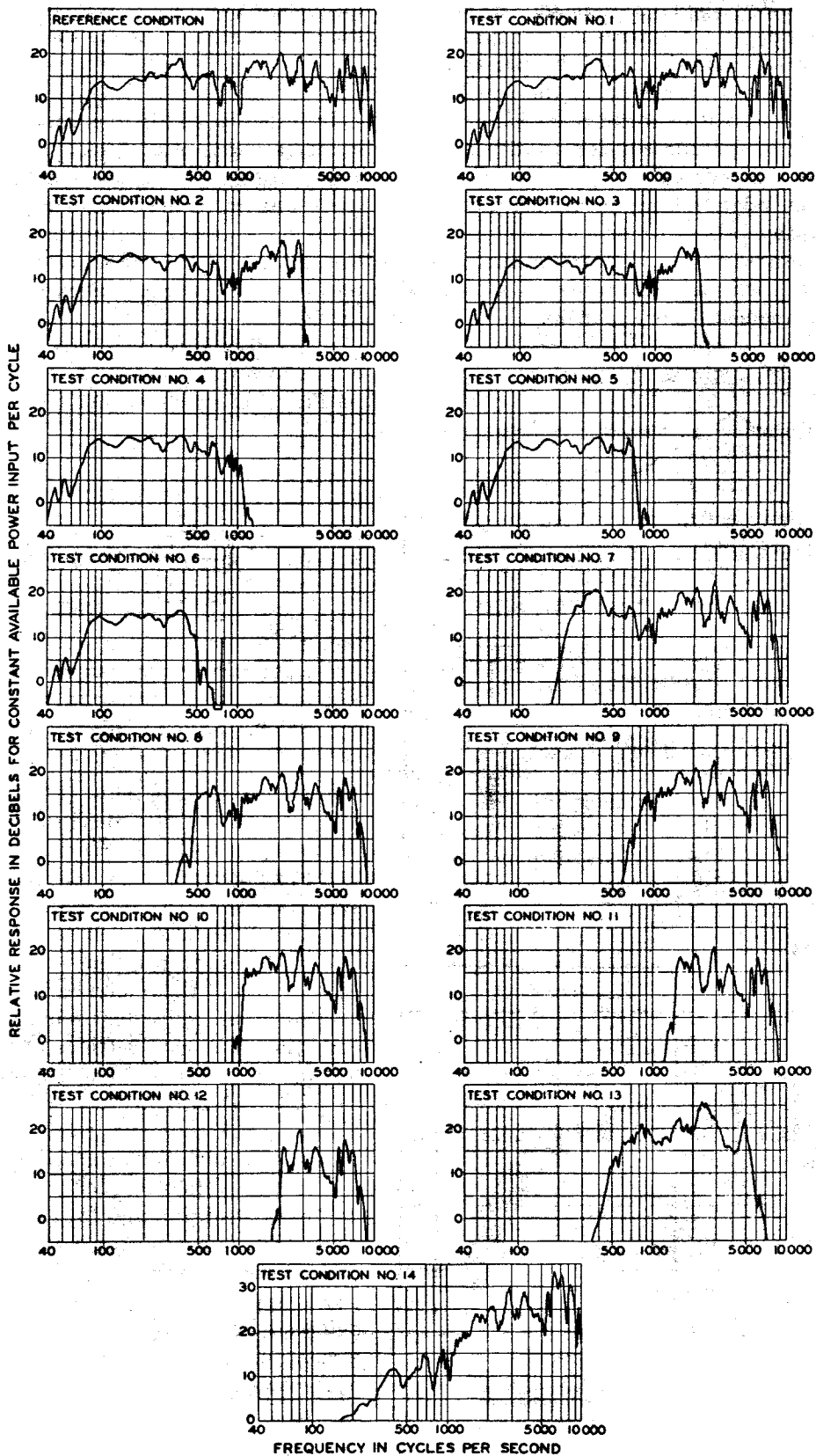

Fig. 9—Response-versus-frequency characteristics of loudspeaker used for the reference and test conditions.

watt input was readily obtained for each test condition. These data and the loudness-efficiency factors, computed from (9), (10) and (11), are shown in Table I. It will be observed that the effective pressures for the unweighted

power supply deviate materially from those for the weighted conditions as the frequency range is decreased and the response is made less uniform. This deviation is negative for the low-pass and positive for the high-pass filter conditions. The loudness-efficiency factor for each of the test conditions relative to that for reference condition is expressed in decibels in the last column of the table. If this method of rating loudspeakers is valid, the relative loudness of the loudspeaker conditions represented when judged by an observer listening to speech and music should confirm the data in this column.

To provide the desired correlation of the measured data with aural observations, listening tests were conducted in a room 26×18×12 feet. The observer was located 15 feet away from and in front of the reference and test loudspeakers, which were placed as closely as possible to one another at one end of the room. A switch was provided to permit a quick change to be made from the reference to the test condition. The source material consisted of selected speech and orchestral records. For all tests, the intensity level supplied by the reference speaker at the observer's position was maintained at 68 db for speech and 91 db for music, as indicated by a sound meter. The power in the test loudspeaker was adjusted until the observer judged that reproduction from the reference and test loudspeakers was equally loud. Six observers made judgments for all conditions, while one judged only a few conditions. The resultant data are shown in Table II. The variation in loudness judgment among the observers is surprisingly small except in the cases where highly distorted systems are involved. The loudness for speech reproduction is observed to be approximately the same as that for music for all low-pass filter conditions, but an increasing de-

parture from equality is shown to exist as the cutoff frequency of the high-pass filter condition is raised.

In order to express the aural data in a form which permits comparison with the measured data, the observations for speech and music were averaged together for each condition. These data and the comparable measured data from Table I are shown in the last two columns of Table II. It is observed that very good agreement exists for all except high-pass filter conditions having cutoff frequencies above 1100 cycles per second. It is doubtful if any loudspeaker having distortion as great as this would ever be used in any normal sound reproducing system. The reason for the discrepancy that appears for the high-pass filter conditions will be made evident in later discussion. This experimental work indicates that, from a practical standpoint, a satisfactory measure of the relative loudness for a wide range of loudspeaker conditions may be obtained by the proposed method.

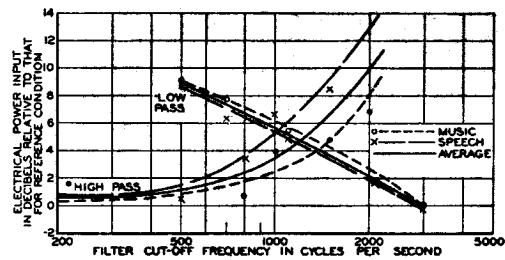

Fig. 10—Power input versus spectrum range of speech and music for equal loudness in a room.

As indicated by the response curves of Fig. 9, the relative pass-band efficiencies are different for the vari-

TABLE I
LOUDNESS MEASUREMENTS OF REFERENCE AND TEST LOUDSPEAKERS

Loudspeaker condition	Effective Pressure p_{ax} (dyne/cm. ²) at 3 feet for 1 watt of sweep-frequency power		Loudness directivity index K_1	Intensity level at 30 feet $L_{I_{ax}}$ in db relative to 10 ⁻¹⁶ watts/cm. ²	Loudness efficiency factor LR —%	Loudness efficiency factor of test condition relative to that of the reference condition in db.
	Weighted ¹⁶	Unweighted		Weighted		
Reference—728-B #1	19	18.6	7.0	79.6	1.89	0
1—728-B #2	17	16.2	7.0	78.6	1.51	- 1.0
2—Condition 1+3000~LP	14	12.9	7.0	76.9	1.02	- 2.7
3—Condition 1+2100~LP	10	9.0	7.0	74.0	0.525	- 5.6
4—Condition 1+1100~LP	6.0	4.2	7.0	69.9	0.293	-10.0
5—Condition 1+ 700~LP	4.9	3.5	7.0	67.8	0.126	-11.8
6—Condition 1+ 500~LP	4.0	2.6	7.0	66.0	0.0825	-13.5
7—Condition 1+ 230~HP	18	17.6	7.0	79.1	1.69	- 0.5
8—Condition 1+ 500~HP	13.7	14.7	7.0	76.7	0.966	- 2.8
9—Condition 1+ 800~HP	14.7	15.7	7.0	77.4	1.14	- 2.2
10—Condition 1+1100~HP	12.0	14.4	7.0	75.6	0.75	- 4.0
11—Condition 1+1500~HP	9.6	11.3	7.0	73.6	0.475	- 6.0
12—Condition 1+2100~HP	6.2	7.1	7.0	69.8	0.205	- 9.7
13—D-173181	24	27	4.8	81.6	4.98	+ 4.2
14—Condition 1+6-db-per-octave network	9.2	11.0	7.0	73.3	0.477	- 6.3

¹⁶ Weighted in accordance with equalization of Fig. 6. These values were used in determining loudness-efficiency factors.

ous test conditions. The system was purposely adjusted to provide these differences so that a range of loudness efficiencies would be encompassed by the tests. However, since the loudspeaker response is relatively flat, a fundamental loudness relationship of considerable interest may be shown by correcting the test conditions for equal passed-band efficiencies. This is the condition that would exist if perfect filters were inserted in the transmission system. The aural data corrected in this manner were plotted as shown on Fig. 10 to indicate

this relationship. The ordinates of the curves represent the power required for a loudspeaker having a limited frequency range relative to that for a loudspeaker of the same relative efficiency per cycle reproducing the complete spectrum of speech and music at equal loudness. Since the response of the system is flat, the ordinates are also a measure of the relative intensity levels in the room. For the low-pass filter conditions, the curves are similar for speech and music. For the high-pass filter conditions, however, the relative in-

TABLE II
LOUDNESS JUDGMENT TESTS

Test condition versus reference condition	Ratio in Decibels of Electrical Power in Reference Loudspeaker Relative to that in Test Loudspeaker for Equal Loudness										Loudness efficiency factor of test condition relative to that of reference condition in decibels from Table I
	Observer 1	Observer 2	Observer 3	Observer 4	Observer 5	Observer 6	Observer 7	Average for all observers	Range of observations in decibels	Average for speech and music	
1. 728-B #2 Speech Music	0 0	0 0	0 0	-1 -1	-1 -1	-1 0	-1 0	-0.6 -0.3	1 1	-0.4	-1.0
2. Condition 1+3000~LP Speech Music	-2	-2.5 -4	-4 -4	-3 -3	-3 -3	-3 -1	-3 -2	-2.9 -2.7	2 3	-2.8	-2.7
3. Condition 1+2100~LP Speech Music	-7	-4 -4	-5 -4	-5.5 -8	-6.5 -8	-6 -8	-6 -8	-5.6 -6.2	3 4	-5.9	-5.6
4. Condition 1+1100~LP Speech Music	-11 -11	-10 -9	-10 -9	-9 -10	-9 -10	-9 -10	-9 -10	-9.5 -9.8	2 2	-9.7	-10.0
5. Condition 1+ 700~LP Speech Music	-12	-12 -12	-13 -11	-11 -14	-12 -14	-8 -10	-8 -11	-10.4 -11.75	5 4	-11.1	-11.8
6. Condition 1+ 500~LP Speech Music		-14 -13	-15 -13	-15 -16	-14 -16	-13 -14	-14 -13	-14.1 -14.0	2 3	-14.0	-13.5
7. Condition 1+ 230~HP Speech Music	-2	-1 -2.5	-1 -1	-2 0	-1 0	0 -1	-1 -1	-1 0.85	2 2.5	-0.9	-0.5
8. Condition 1+ 480~HP Speech Music				-1 -2	-1 -2	-3 -3	-3 -3	-1.9 -2.5	2 1	-2.2	-2.8
9. Condition 1+ 800~HP Speech Music				-3 -1	-3 -1	-6 -2	-6 -1	-4.2 -1.2	3 1	-2.5	-2.2
10. Condition 1+1100~HP Speech Music	-12	-10 -7	-9 -6	-5 -4	-5 -4	-11 -7	-12 -5	-7.8 -5.3	7 3	-6.4	-4.0
11. Condition 1+1500~HP Speech Music		-10 -10	-11 -8	-9 -10	-9 -11	-15 -4	-14 -4	-10.8 -7.2	6 7	-8.6	-6.0
12. Condition 1+2000~HP Speech Music		-15 -14	-16 -8	-13 -11	-13 -10	-20 -9	-18 -7	-15.1 -9.3	7 7	-11.3	-9.7
13. D-173181 Speech Music	+2	+1.5 +4	+2 +4	+3 +4	+3 +4	+2 +4.0	+2 +5	+2.2 +4.2	1.5 1.0	+3.1	+4.2
14. Condition 1+6-db-per- octave network Speech Music	-10	-10 -7	-10 -7	-8 -5	-7 -8	-10 -4	-9 -4	-9 -5.5	3 4	-7	-6.3

tensities for speech differ materially from those for music for cutoff frequencies above 1000 c.p.s. due to the differences in their energy spectra. The point at which the high-pass and low-pass curves intersect represents the frequency at which the loudness is equally divided. This intersection point for speech occurs at a frequency of 1000 c.p.s. The reduction in intensity at this point is about 5 db, whereas Munson's earlier data, obtained with headphone receivers, indicated a value of 10 db. The only apparent explanation for this difference is that the acoustic environment existing when listening to a loudspeaker in a room is quite different from that existing when headphone receivers are used.

The average curve from Fig. 10 has been replotted on Fig. 11 for comparison with similarly treated measured

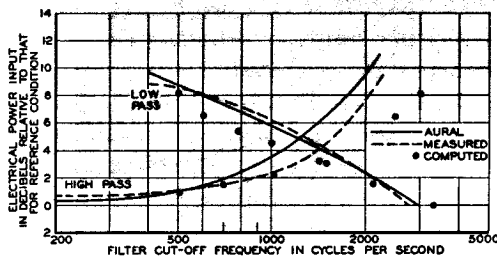

Fig. 11—Averaged power input versus spectrum range of speech or music for equal loudness in a room, as determined by aural, measured, and computed methods.

data and computed values. The computations were made using the applicable response-versus-frequency characteristics of Fig. 9 and the loudness-weighting characteristic of Fig. 6. The difference between the computed and measured data is due to the nonuniformity of the energy distribution with frequency in the sweep-frequency power applied as indicated in Fig. 7. From the curves, it may be concluded that the choice of this type of sweep-frequency power results in measured values of relative loudness which are in close agreement with the aural data.

ACOUSTIC POWER REQUIREMENTS IN ENCLOSURES

When a loudspeaker projects sound into an enclosure, its acoustic performance as determined under open-air conditions is modified by the acoustic properties of the space, but the total power radiated is essentially unchanged. If the enclosure has very high absorption, the direct energy predominates and the characteristics of the loudspeaker will be similar to those for open air. The more live the room becomes, the more the reflected energy will predominate and, therefore, the greater will be the effect upon the radiation from the loudspeaker.

When a source of sound is started in a room, the energy spreads from the source and then strikes the various wall surfaces, where it is partially absorbed and partially reflected to other surfaces, where again it is partially absorbed and partially reflected. This process continues until the energy in the room builds up to a

steady-state value, when the rate of absorption at the various surfaces and in the air is equal to the emission of energy from the source. At any point in the room, then, the energy density may be conveniently considered to be made up of two parts. One portion is contributed by direct radiation from the source and is equal to that which would be established at the point if the walls of the room were removed and the source were radiating into free space. The second portion is made up of energy which has been reflected one or more times from the various surfaces of the room. The first will be called the direct and the second the reverberant energy. The direct energy is distributed according to the inverse square law, while the reverberant may be considered as random in direction and uniform in distribution throughout the volume of the room.

The total energy in a room in the steady state is taken as¹⁷

$$\rho_{av}V = \frac{4EV}{\alpha S_R c} \quad (12)$$

in which

V = volume of the room

ρ_{av} = average energy density

E = rate at which the source emits energy

α = average absorption coefficient for the surfaces of the room

S_R = the total surface area of the room

c = velocity of sound.

This energy is made up of the total reverberant energy, assumed uniform in distribution, and the total direct energy. The reverberant energy is obtained by subtracting from (12) the total direct energy which depends upon the directional characteristics of the source and the position of the source in the room. Thus, if the source radiates uniformly in all directions (a point source), the direct energy will be a maximum when the source is in the center of the room; while if the radiation is concentrated in a relatively small solid angle, the direct energy will be a maximum when the source is at the side of the room and the energy radiated toward the center. Let us assume that the direct energy is that contained in a sphere having the source at its center and a radius equal to the mean free path between reflections in the room.¹⁸⁻²⁰ Such a sphere will have a volume very nearly equal to that of the room for all rooms of reasonable proportions. The two volumes will be equal if the mean free path is taken as $0.63^3\sqrt{V}$, while accepted values of the mean-free-path range from $0.63^3\sqrt{V}$ to $4V/S_R$

¹⁷ V. O. Knudsen, "Architectural Acoustics," John Wiley and Sons, New York, N. Y., 1932, p. 127.

¹⁸ E. R. Eyring, "Reverberation time in 'dead' rooms," *Jour. Acous. Soc. Amer.*, vol. 1, pt. I, pp. 217-241; January, 1930.

¹⁹ See p. 137 of footnote reference 17.

²⁰ E. H. Bedell, unpublished work.

If we use the value $4V/S_R$, the total direct energy contained in such a sphere is

$$\rho_d V = \frac{4EV}{S_{RC}} \quad (13)$$

where ρ_d is the average direct energy density. The total reverberant energy in the room is then

$$\rho_r V = \frac{4EV}{\alpha S_{RC}} - \frac{4EV}{S_{RC}} \quad (14)$$

where the average reverberant energy density²¹ ρ_r is

$$\rho_r = \frac{4E}{S_{RC}} \left(\frac{1 - \alpha}{\alpha} \right) \quad (15)$$

The direct energy density ρ_d due to radiation from a point source at a point distant r from the source is

$$\rho_d = \frac{E}{4\pi r^2 c} \quad (16)$$

If the source does not radiate uniformly,

$$\rho_d = \frac{EQ}{4\pi r^2 c} \quad (17)$$

in which $Q = 4\pi/\Omega$, Ω being the solid angle of radiation which is related to the directivity.

The average energy density ρ_{av} at any point within the enclosure is the sum of the direct and reverberant energy density ρ_d and ρ_r .

$$\begin{aligned} \rho_{av} &= \frac{E \cdot Q}{4\pi r^2 c} + \frac{4E(1 - \alpha)}{S_{RC}\alpha} \\ &= \frac{E}{4\pi c} \left[\frac{Q}{r^2} + \frac{16\pi}{R} \right] \end{aligned} \quad (18)$$

in which $\alpha S_{RC}/1 - \alpha$ is defined as the room coefficient R because of its flexible use in practical problems.

From (18) it is possible to determine the manner in which the average energy density varies with the distance from the source in enclosures having various room coefficients. It is also useful to determine this variation relative to an arbitrary open-air condition ($R = \infty$), using $r = 1$ as a reference since it is intended to refer an axial-pressure measurement of a loudspeaker made under open-air conditions to that which would exist in an enclosure. Thus, the ratio of the average energy density in an enclosure relative to the reference open-air condition, expressed in decibels, is

$$\begin{aligned} \delta &= 10 \log_{10} \frac{\rho_{av \text{ encl}}}{\rho_{av \text{ open air at } r=1}} \\ &= 10 \log_{10} \left[\frac{Q}{r^2} + \frac{16\pi}{R} \right] \end{aligned} \quad (19)$$

²¹ H. F. Olsen and F. Massa, "Applied Acoustics," P. Blakiston's Son and Co., Philadelphia, Pa., second edition, 1939.

This relationship for point-source radiation ($Q = 1$) is plotted on Fig. 12 for various values of room coefficient. These results are independent of the power radiated by the source. These curves show that it is possible to obtain a substantial increase in energy density in a room as compared to that for open air. Since point-source radiation was assumed in obtaining the curves of Fig. 12,

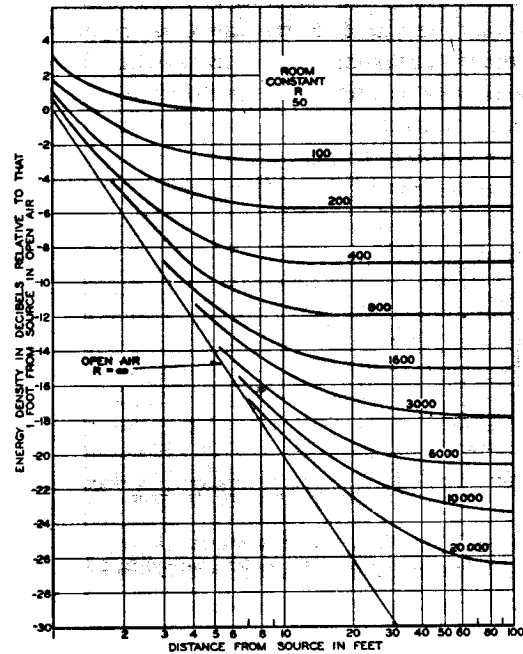

Fig. 12—Average energy density versus distance from the source for enclosures having various room coefficients relative to the energy density at 1 foot from the source in open air, expressed in decibels; point-source radiation assumed.

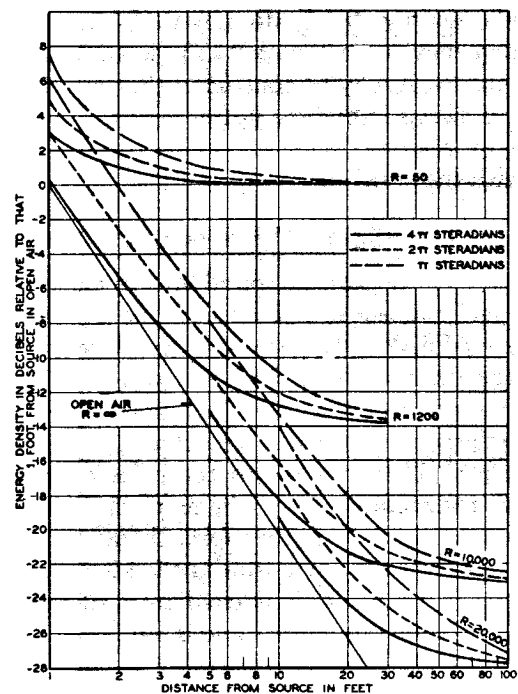

Fig. 13—Curves showing the effect of the directivity of the source on the average energy density in enclosures having various room coefficients.

the effects of the directivity of the source on these relationships must be determined before applying the results to practical conditions.

The effect of the directivity of the source may be determined readily by assuming various values of Q in (19). Curves illustrating this effect have been plotted on Fig. 13, for values of Q of 1, 2, and 4 for a range of room coefficients. Values of Q greater than 4 are not likely to be encountered in practice. It will be observed from the curves that the effect of directivity upon the energy density is small for distances of 30 feet or more, except for extremely large enclosures where R is large.

Consideration of this data indicates the fact that, if a representative distance from the source is selected, a gain in energy density over that for open air can be determined. It is observed that, beyond distances of 10 feet in small rooms and 30 feet in large rooms, the energy density remains constant and is practically all reflected energy. This fact is important because it permits the evaluation of the intensity throughout an enclosure from a single point observation. This suggests the use of 30 feet as a reference distance from the source. If the axial-pressure measurement p_{ax} of a loudspeaker under open-air conditions is made at a distance of 30 feet or corrected to the value that would exist at that distance, a room gain factor K_2 , may be computed for any enclosure. This factor represents the gain in intensity level that would exist in an enclosure relative to that measured in open air at a distance of 30 feet for a given available power input.

The room gain factor may be computed as a function of room volume if it is assumed that all enclosures have an optimum reverberation time. The optimum reverberation time of enclosures has been determined by many investigators.²²⁻²⁵ Average values of these data are shown on Fig. 14. It has been established that the shape of the room will have a negligible effect upon the results.

The value of K_2 may be obtained directly from Fig. 12 if the room coefficient R is known, or it may be computed in the following manner:

According to Eyring,¹⁸ the reverberation time T of an enclosure in seconds is

$$T = \frac{0.05V}{-S_R \ln(1 - \alpha)} \quad (20)$$

in which

V = volume of the room in cubic feet

S_R = the total surface area of the room in square feet

α = the average absorption coefficient.

²² Watson Architecture, May, 1927.

²³ S. Lifschitz, "Acoustics of large auditoriums," *Jour. Acous. Soc. Amer.*, vol. 4, pp. 112-121; October, 1932.

²⁴ P. E. Sabine, "Acoustics of sound recording rooms," *Trans. Soc. Mot. Pic. Eng.*, vol. 12, pp. 809-813; September, 1928.

²⁵ W. A. MacNair, "Optimum reverberation time for auditoriums," *Jour. Acous. Soc. Amer.*, vol. 1, pt. 1, pp. 242-248; January, 1930.

Letting $\Delta = 0.05V/S_R$ and substituting in (20),

$$\alpha = 1 - e^{-\Delta/T}. \quad (21)$$

Since $R = \alpha S_R / (1 - \alpha)$, by substitution

$$R = S_R(e^{\Delta/T} - 1). \quad (22)$$

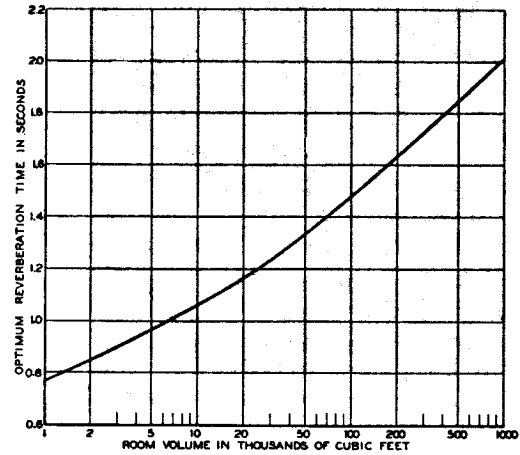

Fig. 14.—Optimum reverberation time as a function of room volume (512 c.p.s.).

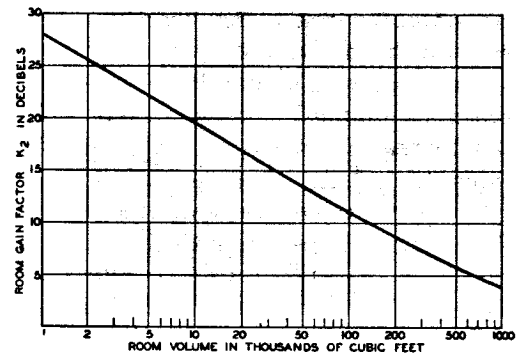

Fig. 15—Room gain factor for rooms having optimum reverberation times.

From Fig. 12, the ratio of the energy density at 30 feet to that at 1 foot in open air expressed in decibels is

$$L_0 = 10 \log_{10} \frac{1}{30^2} \quad (23)$$

$$= -29.54 \text{ db.}$$

From (19), (22), and (23) it is readily shown that, at a reference distance of 30 feet, the total gain in the energy density K_2 due to moving the source from open air to an enclosure is

$$K_2 = 10 \log_{10} \left[\frac{Q}{r^2} + \frac{16\pi}{S_R(e^{\Delta/T} - 1)} \right] - L_0. \quad (24)$$

If only the first three terms of the exponential series for e^x are employed, (24) reduces to

$$K_2 = 10 \log_{10} \left[\frac{Q}{r^2} + \frac{1000T}{V \left[1 + \frac{0.05V}{2S_R T} \right]} \right] - L_0. \quad (25)$$

The error introduced by this approximation will be a maximum of 10 per cent for a room volume of 10^6 cubic feet, and will be only 1 per cent for a room volume of 10^8 cubic feet. Values of K_2 , computed from (25) for optimum reverberation time, are shown on Fig. 15. If the reverberation time differs from optimum by ± 30 per cent, the error will be 1.4 db. If the reverberation time is known, an approximate correction of the room factor may be obtained by assuming the acoustic power to be inversely proportional to the reverberation time for a given room volume.

It is now necessary to establish representative sound levels for the reproduction of speech and music in enclosures. Since Fletcher⁶ has tabulated the required data, only a brief summary of this information is given in Table III.

As indicated in columns 1, 2, and 3 of this table, maximum peaks of speech or music are about 20 db above the long r.m.s. power indicated by a volume indicator or sound meter, while the maximum r.m.s. power is about 10 db above the volume-indicator value. Amplifier design is frequently based on the maximum r.m.s. power since the peaks that exceed this value are of short duration and occur during a very small percentage (1 to 5 per cent) of the time. The data for conversational speech were obtained at a distance of 20 feet and converted to the levels existing at $2\frac{1}{2}$ feet, as shown in columns 4 and 5. An adequate speech level to be established within the enclosure has been selected as the level existing at $2\frac{1}{2}$ feet from the lips of a person talking conversationally, as indicated in columns 6 and 7. The levels shown in column 6 of the table are applicable for

amplifier design. From the table it is evident that a maximum r.m.s. intensity level of 78 db for speech, 96 db for small orchestras, and 106 db for large orchestras should be established in an enclosure for adequate reproduction.

From the above data, the acoustic power required for a specified intensity level in any enclosure may be computed. The maximum acoustic power radiated from a point source throughout a solid angle of 4π steradians in open air may be determined from (4) and (5). For the required intensity levels of 106, 96, and 78 db, the maximum r.m.s. acoustic power W_{a1} is 41.2, 4.12, and 0.065 acoustic watts, respectively. Applying the room gain factor K_2 , the maximum acoustic power W_{a2} required for the desired levels of speech and music for any room volume having an optimum reverberation may be obtained from

$$W_{a2} = W_{a1} 10^{(K_2/10)}. \quad (26)$$

Values so computed are shown on Fig. 16. The optimum reverberation time at a frequency of 512 cycles was used in order to simplify the computation of power.

However, MacNair²⁵ has shown that, for the loudness of all pure tones to decay at the same rate as the sensation level at all frequencies, which is our premise, the optimum reverberation time for a given enclosure must change with frequency. It is constant between frequencies of 700 and 4000 cycles and about one-half of this value at a frequency of 100 cycles. Using MacNair's data and the midband frequencies of the equal loudness increments (Fig. 3), the values of K_2 were recomputed for various room volumes, and found to be within one-half of a decibel of the values obtained for a frequency of 514 cycles. Therefore, the ordinates of Fig. 16 are an adequate indication of required power based on loudness.

TABLE III
SOUND LEVELS FOR SPEECH AND MUSIC

Type of sound	Maximum peak intensity level	Amplifier design maximum r.m.s. $\frac{1}{2}$ second	Volume indicator reading long r.m.s.	Desired Levels within Enclosure			
				Speech Levels Normal for 2.5-Foot Distance			
				Recommended for amplifier design	Volume indicator	Recommended for amplifier design	Volume indicator
Conversational speech	(1)	(2)	(3)	(4)	(5)	(6)	(7)
Men	66.5	56.5	46.5	78	68	78	68
Women	64.5	54.5	44.5	76	66		
Music							
1 voice	97	87	77			87	77
100 voices	117	107	97			107	97
75-piece orchestra	116	106	96			106	96
18-piece orchestra	106	96	86			96	86

In many cases, reproduction may be required in noisy places. It is always desirable to maintain the signal-to-noise ratio a maximum. However, when the noise level is very high (90 to 100 db), a signal-intensity level of 10 db above the noise level²⁶ is sufficient for adequate intelligibility of speech, in which case the 78-db noise level assumed for speech reproduction may have to be increased. The acoustic power required for this condition will then exceed the values shown on Fig. 16 by an equivalent amount.

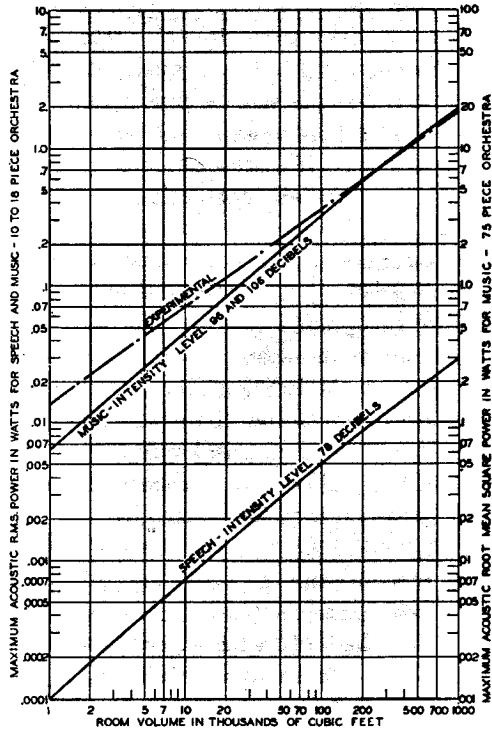

Fig. 16—Maximum r.m.s. acoustic power as a function of room volume for intensity levels of 78 db for speech and 96 and 106 db for music.

The solid curves of Fig. 16 show the computed relationship between room volume and the acoustic power required to reproduce speech and music at intensity levels of 78, 96, and 106 db. The curve indicated by the broken line of the figure represents the listening judgment of many observers on the basis of satisfactory or "pleasing" sound levels. It will be observed that close agreement between computed and empirical data exists at larger room volumes. The agreement is found to be somewhat poorer in the case of small rooms, where a maximum deviation of 3 db occurs. Since the empirical data is based on personal judgment, it is difficult to reconcile these differences. The computed levels of 78, 96, and 106 db for speech and music would appear to be at least adequate. In determining power requirements, however, it may be well to bear in mind that in small rooms a somewhat higher power may be necessary for satisfactory psychological effects. Fortunately, the de-

²⁶ N. R. French, unpublished data.

viation becomes appreciable only in small rooms where relatively little power is needed.

Amplifier Power

The amplifier capacity required for various enclosures determined by converting the ordinate of Fig. 16 to electrical watts for various values of the loudness-efficiency factor LR are shown on Figs. 17 and 18. The

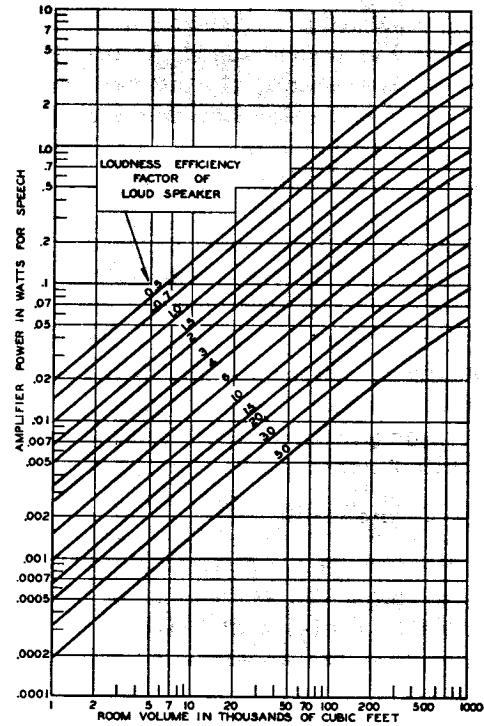

Fig. 17—Required amplifier power for speech as a function of room volume for various loudness-efficiency factors.

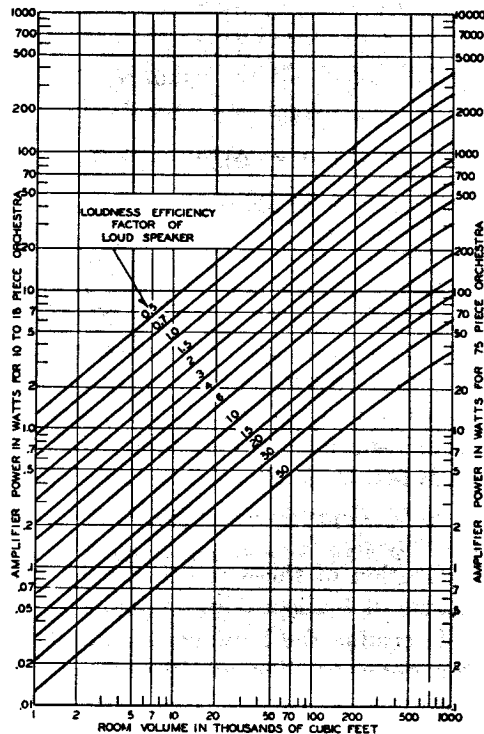

Fig. 18—Required amplifier power for music as a function of room volume for various loudness-efficiency factors.

number of loudspeakers required may be determined by dividing the required amplifier power by W_{ec} , the power capacity of the loudspeaker.

Application

The following illustrative example may serve to clarify the application of the foregoing proposals. A power source having a sweep-frequency rate of 5 to 10 per second and covering the frequency range from 300 to 3300 cycles, equalized in accordance with the characteristic shown on Fig. 6, is assumed. An open-circuit voltage of 31 volts is applied to the test circuit of a 12-inch direct-radiator loudspeaker having a rating impedance of 8 ohms. The available power will then be 30 watts, which is assumed to be the power-capacity rating of the loudspeaker. Under this condition, the sound pressure at 6 feet on the axis of the speaker is measured in open air and found to be 50 dynes per square centimeter. The intensity level as indicated by a sound-level meter would be 108 db. From these data it is now possible to determine the loudness-efficiency factor of the loudspeaker, the amplifier power necessary for the prescribed levels of reproduction for speech and music in any enclosure, and the number of loudspeakers required.

A pressure of 50 dynes per square centimeter obtained at an axial distance of 6 feet corresponds to an intensity level of 94 db relative to 10^{-16} watts/cm.² when extrapolated for a distance of 30 feet. Since W_{ec} is 30 watts, $k=14.78$ db relative to 1 watt, and K_1 from Fig. 26 in the Appendix is 6.8 db, substituting in (9), (10), and (11).

$$\begin{aligned} L_e &= L_{ax} - 89.8 - k - K_1 \\ &= 94 - 89.8 - 14.8 - 6.8 \\ &= -17.4 \text{ db} \\ W_{Le} &= 10^{-17.4/10} \\ &= .0183 \\ LR &= 100 \times .0183 \\ &= 1.83 \text{ per cent.} \end{aligned}$$

For the reproduction of speech and music in a room having a volume of 10^6 cubic feet and an optimum reverberation time, Figs. 17 and 18 indicate that, when LR is 1.83 per cent, an amplifier power of 980 watts is required for music from large orchestras, 98 watts for small orchestras, and 1.53 watts for speech. One loudspeaker is sufficient for the reproduction of speech, three loudspeakers for music from small orchestras, while 33 loudspeakers are required when music from large orchestras is reproduced.

The application of these results would require that manufacturers of loudspeakers make certain measurements to determine the loudness rating of their product. Such a determination would require that the following conditions be met:

(1) Tests should be made in open air or in a dead room without reflections above 300 cycles.

(2) The pressure measurement should be made on the geometric axis of the loudspeaker at a distance that is at least three times the maximum transverse dimension of the radiating area. The resulting pressure should be corrected to that which would exist at a distance of 30 feet, employing the inverse-square law.

(3) The electrical supply for the test should be a 300- to 3300-cycle sweep-frequency tone, with the designated weighting equalizer in the circuit. The sweep-frequency source should have a reciprocating linear frequency change with time at a rate of 5 to 10 times per second to obtain an amplitude distribution of the components in accordance with that indicated on Fig. 7.

(4) The pressure p_{ax} , or the intensity level L_{ax} , should be obtained on the axis with a power supply sufficient to drive the loudspeaker at its rated power capacity. If powers lower than W_{ec} are used in making this measurement, the appropriate correction must be made in the formulas.

(5) The loudness rating LR of the loudspeaker may then be obtained from (9), (10), and (11).

It must be recognized that, in addition to loudness, many other factors must be considered in establishing a true merit rating for loudspeakers. Uniformity of frequency response, harmonic distortion, frequency range, intermodulation, damping, and uniformity of distribution all have their effects on the performance of an instrument. These factors are controlled by basic instrument design, and their magnitudes are established by laboratory measurements. Listening tests, if carefully performed, provide a practical method of evaluating the extent to which the factors have been controlled and the suitability of an instrument for its intended use. Instruments for special or scientific uses require, of course, more careful selection.

In spite of the various compromises and assumptions which had to be made to arrive at a practical and simple factor for rating loudspeakers, it is believed that the proposed method should give a reasonably accurate measure of effective loudness efficiency. Its use in practice should materially simplify the problems of the sound-systems engineer.

APPENDIX

DERIVATION OF LOUDNESS-DIRECTIVITY INDEX

Typical loudspeaker systems used in practice and the shape of their radiating areas are given in Table IV. The theoretical condition assumed to approximate each practical condition is also shown.

In the analysis of the theoretical conditions, it is assumed that the radiating surface vibrates axially, and that the distance from the source at which the acoustic power is computed is sufficient to insure that the pressure and particle velocity are in phase.

The directivity index may be derived as follows:

Referring to Fig. 19, consider the center of the radiating area to be located at the origin O . At a given dis-

tance r the effective pressure p and the particle velocity ξ are in phase. For this condition, p is equal to $\rho c \xi$ where ρ is the density of the medium and c is the velocity of sound.

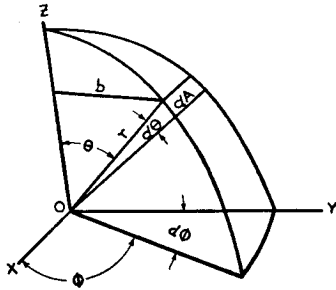

Fig. 19—Source of radiation.

TABLE IV
TYPES OF RADIATION FROM LOUSPEAKERS

Practical Condition		Theoretical condition assumed to approximate practical condition
Type of loudspeaker	Approximate shape of radiating area	
A. <i>Baffled</i>		
Single Unit Horn	Circle	Rigid disk in infinite baffle
Direct radiator	Circle	Rigid disk in infinite baffle
Direct radiator on horn	Rectangle	Rigid rectangular plate in infinite baffle
Sectoral horn	Cylindrical sector	Sectoral radiation in infinite baffle
Multicellular horn	Rectangular spherical sector	Uniform radiation over equivalent solid angle in an infinite baffle
<i>Two Unit</i>		
Direct radiator on horn + sectoral horn	Rectangle + cylindrical sector	Rigid rectangular plate + sectoral radiation in infinite baffle
Direct radiator + sectoral horn	Circle + cylindrical sector	Rigid disk + sectoral radiation in infinite baffle
Direct radiator on horn + multicellular horn	Rectangle + rectangular spherical sector	Rigid rectangular plate + uniform radiation over equivalent solid angle in infinite baffle
Direct radiator + multicellular horn	Circle + rectangular spherical sector	Rigid disk + uniform radiation over equivalent solid angle in infinite baffle
B. <i>Unbaffled</i>		
Horn or direct radiator in small enclosure	Circle	Rigid disk set in sphere

The power radiated from a vibrating area in the XY plane, located at the center of a sphere, is $p^2/\rho c$ per unit area of the spherical surface. Then the power flowing through an elementary area dA of the spherical surface is

$$dP = \frac{p^2}{\rho c} dA. \quad (27)$$

From Fig. 19, the elemental spherical surface is

$$\begin{aligned} dA &= r \sin \theta d\Phi \cdot r d\theta \\ &= r^2 \sin \theta d\theta d\Phi. \end{aligned} \quad (28)$$

If the radiating area is symmetrical about the Z axis, the total power transmitted through the spherical surface is then

$$\begin{aligned} P_t &= \frac{r^2}{\rho c} \int_0^{2\pi} d\Phi \int_0^\pi p^2 \sin \theta d\theta \\ &= \frac{2\pi r^2}{\rho c} \int_0^\pi p^2 \sin \theta d\theta \end{aligned} \quad (29)$$

where p is the effective pressure at any angle θ .

Then the directivity index for radiation over a hemisphere (baffled condition) is

$$D.I._h = -10 \log_{10} \frac{\frac{2\pi r^2}{\rho c} \int_0^{\pi/2} p^2 \sin \theta d\theta}{\frac{2\pi r^2}{\rho c} \int_0^\pi p_{ax}^2 \sin \theta d\theta} \quad (30)$$

where p_{ax} is the axial pressure. Since p_{ax} may be considered constant, the denominator becomes $(4\pi r^2/\rho c)p_{ax}^2$. Let p_θ be the ratio of the pressure at any angle θ relative to p_{ax} ; then

$$D.I._h = -10 \log_{10} \frac{1}{2} \int_0^{\pi/2} p_\theta^2 \sin \theta d\theta. \quad (31)$$

Then the directivity index for radiation over a sphere (unbaffled condition) is

$$D.I._s = -10 \log_{10} \frac{1}{2} \int_0^\pi p_\theta^2 \sin \theta d\theta. \quad (32)$$

The directivity index for the types of radiation assumed in Table IV may now be derived.

Rigid Disk in Infinite Baffle

When a rigid disk located in an infinite rigid baffle vibrates axially in a free fluid, the pressure ratio p_θ of the pressure in space at any angle θ from the normal to that existing at an equal distance on the axis, has been shown by Stenzel^{9,10} to be

$$p_\theta = \frac{2J_1(ka \sin \theta)}{ka \sin \theta} \quad (33)$$

when the distance from the disk is at least five times the disk diameter.

J_1 = Bessel's function of the first order

$$ka = \frac{\pi df}{c} = 2.32 \cdot df \cdot 10^{-4}$$

where d = diameter of disk in inches
 c = velocity of sound in inches per second
 f = frequency in cycles per second.

Substituting (33) in (31) and integrating,²⁷ the directivity index for a rigid disk in a baffle is

$$D.I._h = -10 \log_{10} \frac{1}{(ka)^2} \left[1 - \frac{J_1(2ka)}{ka} \right]. \quad (34)$$

Rigid Rectangular Plate in Infinite Baffle

In this case, (31) for the directivity index cannot be used because the pressure is not uniform on a circle about the axis of the plate in any plane parallel to the plane of the plate. McLachlan²⁸ has shown that, when a rigid rectangular plate of length $2a$ and width $2b$ vibrates axially in an infinitely rigid baffle in the XZ plane, the pressure $p(r, \theta, \Phi)$ in space at an angle θ with respect to the Z axis and at an angle Φ with respect to the X axis in the XY plane, at a distance r from the origin, is

$$p(r, \theta, \Phi) = \frac{2\rho\ddot{\xi}ab}{r} \left[\frac{\sin(ka \sin \theta \cos \Phi)}{ka \sin \theta \cos \Phi} \right] \left[\frac{\sin(kb \cos \theta)}{kb \cos \theta} \right] \quad (35)$$

where ρ is the density of the medium and $\ddot{\xi}$, the acceleration of the plate. The axial pressure p_{ax} on the Y axis is obtained when $\theta = \pi/2$ and $\Phi = \pi/2$, and is

$$p_{ax} = \frac{2\rho\ddot{\xi}ab}{r}.$$

Therefore, the directivity index is

$$D.I._h = -10 \log_{10} \frac{\int_0^\pi \int_0^\pi p^2(r, \theta, \Phi) r^2 \sin \theta d\theta d\Phi}{4\pi r^2 p_{ax}^2} \\ = -10 \log_{10} \frac{1}{4\pi} \int_0^\pi \int_0^\pi \left[\frac{\sin(ka \sin \theta \cos \Phi)}{ka \sin \theta \cos \Phi} \right]^2 \left[\frac{\sin(kb \cos \theta)}{kb \cos \theta} \right]^2 \sin \theta d\theta d\Phi. \quad (36)$$

In an unpublished memorandum, C. T. Molloy has shown that (36) may be transformed into

$$D.I._h = -10 \log_{10} \frac{1}{ka} \int_0^{\pi/2} M(ka \sin \theta) \left[\frac{\sin(kb \cos \theta)}{kb \cos \theta} \right]^2 d\theta \quad (37)$$

in which

$$M(ka \sin \theta) = \frac{1}{2} \left[\int_0^{2ka \sin \theta} J_0(\lambda) d\lambda - J_1(2ka \sin \theta) \right]^{29}$$

The values of $D.I._h$ used in this paper were obtained by a "Simpson's Rule" numerical integration of (37).

Sectoral Radiation in an Infinite Baffle

For the case of radiation from a sectoral horn, rigorous analytical treatment is extremely difficult. With certain assumptions, however, a derivation which approximates the practical condition can be obtained. A radiating area in an infinite baffle was assumed to have a radiation pattern in which the pressure throughout the sectoral angle α is constant over an arc in any given plane parallel to the XY plane, and is zero outside the angle α on this arc. In the vertical direction, the radiation pattern was assumed to be that of a line radiator of length l lying on the z axis with its center at the origin. Further unpublished work of C. T. Molloy has shown that the total power P radiated at a distance r from the source is

$$P = \frac{\alpha p_{ax}^2}{\rho c} \int_0^\pi \left[\frac{\sin ka \cos \theta}{ka \cos \theta} \right]^2 \sin \theta d\theta \quad (38)$$

where θ is the angle between a radius vector from the origin to a field point, and the Z axis and $a = l/2$ and the power from a point source producing the same axial pressure is

$$P_{ax} = \frac{4\pi r^2}{\rho c} p_{ax}^2. \quad (39)$$

The directivity index is, therefore,

$$D.I._h = -10 \log_{10} \frac{\alpha}{4\pi} \int_0^\pi \left[\frac{\sin(ka \cos \theta)}{ka \cos \theta} \right]^2 \sin \theta d\theta, \quad (40)$$

which has been shown by Molloy to reduce to

$$D.I._h = -10 \log_{10} \frac{\alpha}{2\pi} \left[2 \frac{Si(2ka)}{(2ka)} - \left(\frac{\sin ka}{ka} \right)^2 \right]^{30} \quad (41)$$

²⁹ Method of Computation of $\int_0^\alpha J_0(\lambda) d\lambda$: In the interval $0 \leq \alpha \leq 5$ this function is tabulated in "Table of Integrals $\int_0^\alpha J_0(t) dt$ and $\int_0^\alpha Y_0(t) dt$ " by A. N. Lowan and Milton Abramowitz, *Jour. Math. and Phys.*, vol. 22, May, 1943. In the interval $5 \leq \alpha \leq 25$, $\int_0^\alpha J_0(\lambda) d\lambda =$

$$\int_0^\alpha J_0(\lambda) d\lambda - \sqrt{2} [C(10) + S(10)] + \sqrt{2} [C(2\alpha) + S(2\alpha)]$$

where C and S are Fresnel Integrals, and are tabulated in "Functions and Tables" by E. Jahnke and F. Emde, p. 35, 1943, Dover Publications. In the interval $25 \leq \alpha$, use the same formula as for preceding interval, but compute C and S by the following asymptotic formulas:

$$C(2\alpha) = \frac{1}{2} + \frac{\sin(2\alpha)}{\sqrt{4\pi\alpha}} - \frac{\cos(2\alpha)}{4\alpha\sqrt{4\pi\alpha}} \\ S(2\alpha) = \frac{1}{2} - \frac{\cos(2\alpha)}{\sqrt{4\pi\alpha}} - \frac{\sin(2\alpha)}{4\alpha\sqrt{4\pi\alpha}}.$$

The function $J_1(2\alpha)$ may be found in "British Association for the Advancement of Science Mathematical Tables, vol. VI, Bessel Functions," University Press, Cambridge, 1937.

³⁰ The integral sines, Si , are tabulated in Jahnke and Emde, p. 6.

²⁷ N. W. McLachlan, "Bessel Functions for Engineers," Oxford Press, New York, N. Y., 1934; p. 98.

²⁸ N. W. McLachlan, "Loudspeakers," Oxford Press, New York, N. Y., 1934; p. 101.

If $\alpha = \pi$, the directivity index for a line radiator of length $2a$ results; thus,

$$D.I._h = -10 \log_{10} \frac{1}{2} \left[2 \frac{Si(2ka)}{(2ka)} - \left(\frac{\sin ka}{ka} \right)^2 \right]. \quad (42)$$

When a is zero and α is equal to π , the radiator becomes a point source in a baffle. Then $D.I._h = 3$ db.

Uniform Radiation Over a Portion of a Spherical Zone

For this case, the pressure is assumed uniform over an area of a sphere, intercepted by two planes at an angle α passing through the Z axis and two planes at an angle β passing through the X axis.

Referring to (29), the total power transmitted through this surface is

$$P_t = \frac{4p^2 r^2}{\rho c} \int_{\pi/2-\alpha/2}^{\pi/2} d\phi \int_{\cot^{-1}(\tan(\beta/2) \sin \phi)}^{\pi/2 \sin \theta d\theta} \quad (43)$$

Integration of (43) yields:

$$P_t = \frac{4p^2 r^2}{\rho c} \cdot \sin^{-1} \left[\sin \frac{\alpha}{2} \cdot \sin \frac{\beta}{2} \right]. \quad (44)$$

The power from a point source producing the same axial pressure is

$$P_{ax} = \frac{4\pi r^2 p_{ax}^2}{\rho c}. \quad (45)$$

Therefore, the directivity index is

$$D.I._h = -10 \log_{10} \frac{1}{\pi} \sin^{-1} \left[\sin \frac{\alpha}{2} \cdot \sin \frac{\beta}{2} \right]. \quad (46)$$

It is observed that the directivity index for this case is independent of frequency.

Piston Set in Sphere

In this problem, the directivity index may be obtained from (32). Morse³¹ has established the equations for the pressure distribution in space resulting from a rigid piston vibrating axially, set in a sphere of radius a , and subtending an angle $2\theta_0$. Molloy has extended this work to include the actual distribution for a number of specific cases.

The spatial pressure is

$$|p(r, \theta)| = \frac{\mu_0}{2} \frac{(\rho c)}{(kr)} L(\theta) \quad (47)$$

in which μ_0 = the maximum radial velocity of the piston, and the maximum axial pressure is

$$|p_{max}| = \frac{\mu_0}{2} \frac{\rho c}{kr} \cdot L(0) \quad (48)$$

³¹ P. M. Morse, "Vibration and Sound," McGraw-Hill Book Co., New York, N. Y., 1936.

in which

$$L(\theta) = \frac{2}{\mu_0} \left| \sum_{m=0}^{\infty} \frac{U_m}{D_m} e^{i[\delta_m - (m+1)\pi/2]} \cdot P_m(\cos \theta) \right|$$

$$U_m = \frac{\mu_0}{2} [P_{m-1}(\cos \theta_0) - P_{m+1}(\cos \theta_0)]$$

$$D_m = \frac{1}{2m+1} \{ [mj_m(ka) - (m+1)j_{m+1}(ka)]^2 + [mn_m(ka) - (m+1)n_{m+1}(ka)]^2 \}^{1/2}.$$

$$\tan \delta_m = \frac{(mj_{m-1}(ka) - (m+1)j_{m+1}(ka))}{(mn_{m-1}(ka) - (m+1)n_{m+1}(ka))}$$

$P_m(\cos \theta_0)$ = Legendre Polynomial of m^{th} order

$$j_m(ka) = \sqrt{\frac{\pi}{2ka}} \cdot J_{(m+1/2)}(ka)$$

$$n_m(ka) = -1^{m-1} \sqrt{\frac{\pi}{2ka}} \cdot J_{-(m+1/2)}(ka)$$

$$p_\theta = \frac{1}{L(0)} \cdot L(\theta). \quad (49)$$

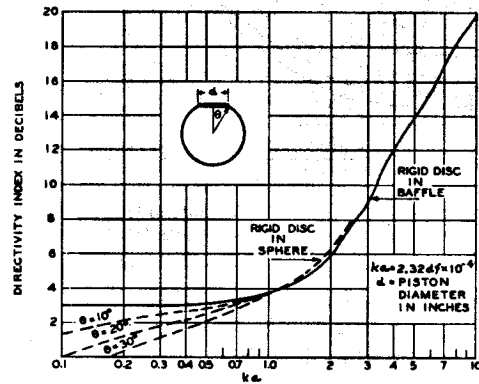

Fig. 20—Directivity index of a rigid disk vibrating axially in an infinite baffle and in a sphere.

Then, substituting in (32), the directivity index is

$$D.I._s = -10 \log_{10} \frac{1}{2L^2(0)} \int_0^\pi L^2(\theta) \sin \theta d\theta \quad (50)$$

or, if $\sigma(\theta) = L^2(\theta)$,

$$D.I._s = -10 \log_{10} \frac{1}{2\sigma_0} \int_0^\pi \sigma(\theta) \sin \theta d\theta. \quad (51)$$

Molloy has also shown that this may be reduced to

$$D.I._s = -10 \log_{10} \frac{S_p k^2}{\pi \sigma_0} \cdot R_s \quad (52)$$

in which

S_p = piston area in square centimeters

R_s = radiation resistance in $\frac{\text{dynes/cm}^2}{\rho c \text{ cm./sec.}}$

$k = \omega/c$.

Equation (51) may be evaluated by numerical integration.

The relation between the directivity index and the argument ka for each of the theoretical radiation conditions is shown on Figs. 20 through 24. These curves reveal interesting relationships between the various conditions of radiation.

Referring to Fig. 20, on which the directivity indexes for a rigid disk in a baffle and in a sphere are plotted, it is observed that, when ka exceeds unity, the directivity indexes are approximately the same for the two conditions. For lower values of ka , the directivity indexes for the rigid disk in a sphere approach those for the baffled condition when θ becomes very small. It is apparent from Fig. 21 that the curve shape for the rectangular

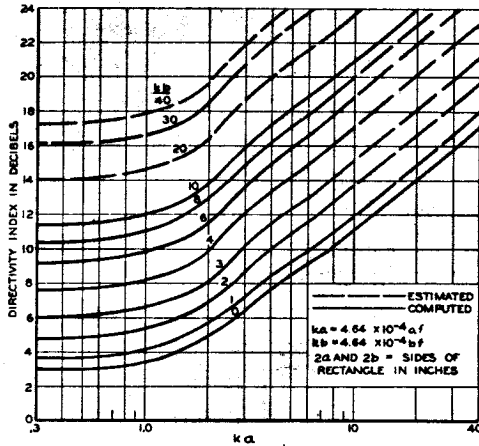

Fig. 21—Directivity index for radiation from a rigid rectangular plate in an infinite baffle.

plate is similar to that for the circular disk. The results of a further investigation of this similarity are shown on Fig. 22, where the directivity indexes are plotted in terms of radiating area for both the disk and the plate. It is observed that the directivity indexes for the circle, square, and rectangle are approximately the same for a given area. These data were computed for a frequency of 1000 c.p.s., but this conclusion applies at any fre-

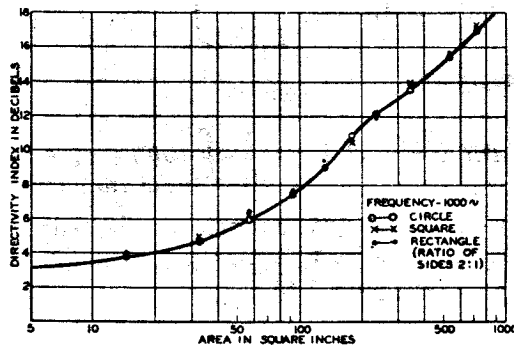

Fig. 22—Directivity index for radiation from a rigid disk and a rectangular plate in an infinite baffle as a function of area.

quency. From Fig. 23, which shows the directivity indexes for sectoral radiation, it should be noted that, when α is equal to 180 degrees, the directivity indexes

apply for radiation from a line of length l . Fig. 24 presents the directivity indexes for radiation from a portion of a spherical zone, a condition which approximates the multicellular horn. Since two variables, α and β , are involved, some simplification in succeeding computations

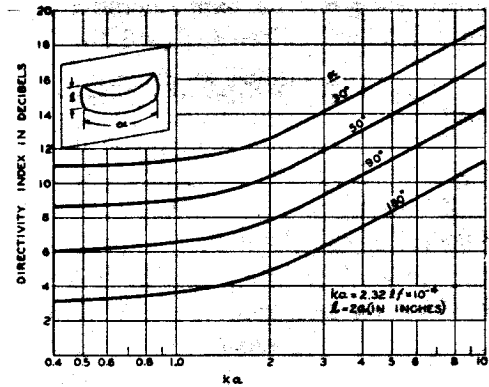

Fig. 23—Directivity index for sectoral radiation in an infinite baffle.

may be attained by expressing the directivity index in terms of the equivalent solid angle of radiation, values for which are shown on the figure.

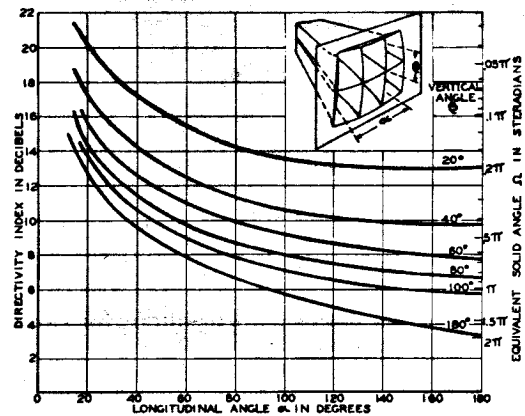

Fig. 24—Directivity index from a portion of a spherical zone in an infinite baffle.

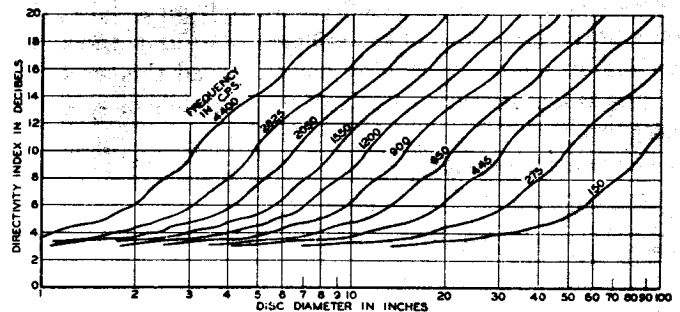

Fig. 25—Directivity indexes of rigid disks of various diameters in an infinite baffle at each of the midfrequencies of the ten equal-loudness bands.

The above data provide a basis for determining the loudness directivity indexes of the various loudspeakers listed in Table IV. The loudness-directivity index of

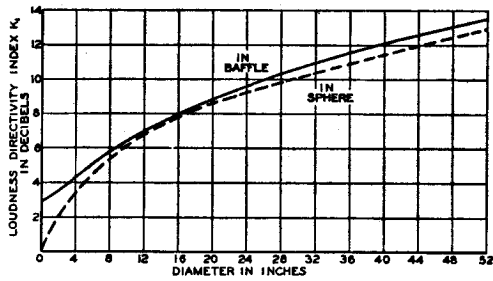

Fig. 26—Loudness-directivity index for radiation from a rigid disk in a sphere and in an infinite baffle (circular horn or direct radiator, baffled or unbaffled).

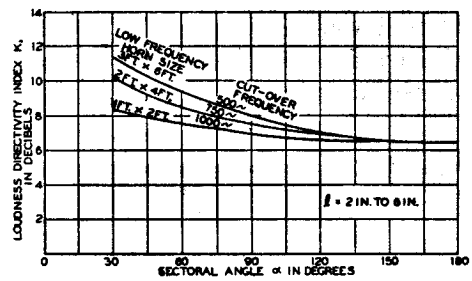
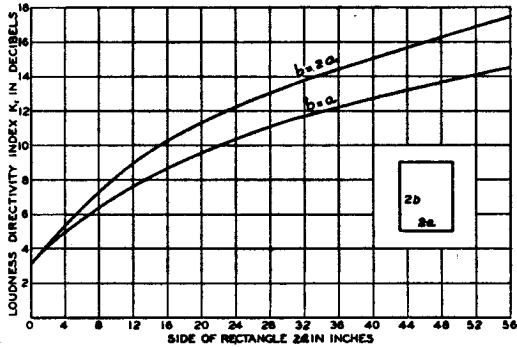

Fig. 30—Loudness-directivity index for a dual system involving sectoral radiation and radiation from a rigid rectangular plate in an infinite baffle (rectangular low-frequency horn and sectoral high-frequency horn, baffled).



27—Loudness-directivity index for radiation from a rigid rectangular plate in an infinite baffle (rectangular horn, baffled).

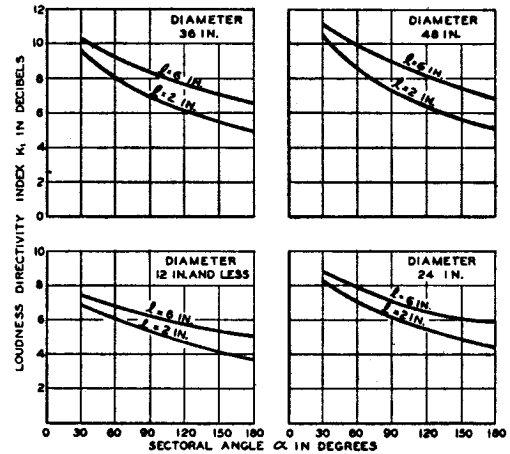

Fig. 31—Loudness-directivity index for a dual system involving sectoral radiation and radiation from a rigid disk in an infinite baffle (circular low-frequency direct radiator and sectoral high-frequency horn, baffled).

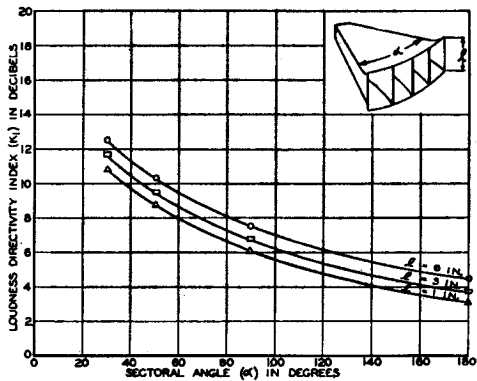

Fig. 28—Loudness-directivity index of sectoral horn.

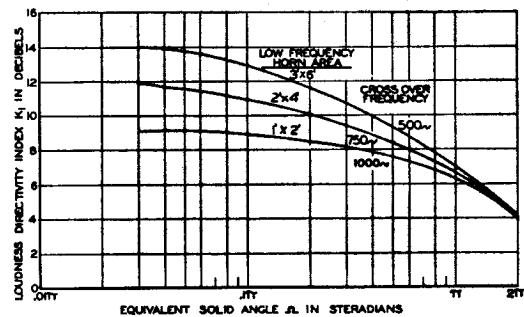

Fig. 32—Loudness-directivity index for a dual system involving radiation from a rigid rectangular plate and a portion of a spherical zone in an infinite baffle (rectangular low-frequency horn and a multicellular high-frequency horn, baffled).

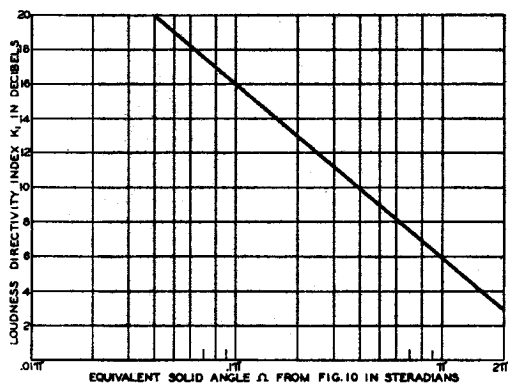

Fig. 29—Loudness-directivity index for radiation from a portion of a spherical zone in an infinite baffle (multicellular horn, baffled).

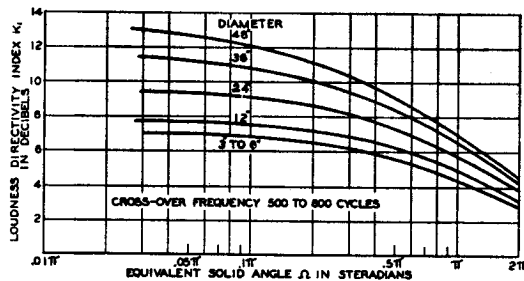

Fig. 33—Loudness-directivity index for a dual system involving radiation from a rigid disk and a portion of a spherical zone in an infinite baffle (circular low-frequency direct radiator and a multicellular high-frequency horn, baffled).

any radiating device may be defined as the average of the directivity indexes for the ten midfrequencies of the equal loudness bands, and may be expressed as follows:

$$K_1 = -10 \log_{10} \left(\frac{10^{-DI_{f_1}/10} + 10^{-DI_{f_2}/10} + \dots + 10^{DI_{f_{10}}/10}}{10} \right) \quad (53)$$

where f_1 to f_{10} are the midfrequencies of the equal-loudness bands shown on Fig. 3. The loudness-directivity in-

dex may be obtained graphically by making use of curves such as those shown on Fig. 25 for the rigid disk in an infinite baffle. Thus, for various types of radiation the loudness-directivity index may be determined in terms of the dimensions of the radiating device. The loudness-directivity indexes for loudspeakers of the types listed in Table IV have been determined in this manner for a range of practical sizes, and they are shown graphically on Figs. 26 through 33.