



288-8H (16H) High Frequency Compression Driver



DISCUSSION

“Not everything that counts can be counted and not everything that can be counted counts.” — Albert Einstein

Great Plains Audio has received many requests from professionals all around the world to once again manufacture transducers with AlNiCo magnets.

Why do our most legendary customers insist on motor structures with AlNiCo magnets? Because these customers know ‘that sound’. The artists have performed for many years and know what gear is essential to achieve ‘that sound’. Those who are in production or post production, responsible for adjusting a perfect mixture (mix) of all the performance parts, also know the equipment they need for ‘that sound’.

Why is ‘that sound’ exclusive to drivers built with AlNiCo magnets? As our Great Plains Audio owner, Bill Hanuschak has stated, “We can’t measure the flux density in a driver motor when it is operating.” In physics, this would be an example of the observer effect, which notes that some measurements of certain systems cannot be made without affecting the systems being measured. This observer effect concept is truly easier to grasp than the concept of Heisenberg’s uncertainty principle (which offers an observer effect at the quantum level). But the explanation for the preferred sound of an AlNiCo magnet driver over the sound of the same driver with a ferrite magnet might only have a complex explanation, and may be best represented through quantum mechanics, for the uncertainty principle is inherent in the properties of all wave-like systems.

However, the explanation for the preferred sound of an AlNiCo magnet driver over the sound of the same driver with a ferrite magnet may be simple. Even though it hasn’t been proven, some

have theorized that although the flux density of a ferrite magnet motor is the same as the flux density of an equally charged AlNiCo magnet motor when both motors are at rest, once their voice-coils are charged with voltages from amplifiers, the flux density of the AlNiCo motor is more dynamic than that of the ferrite motor. Compared to the relatively firm flux density of a ferrite magnet or neodymium magnet, the flux density of an equally charged AlNiCo magnet may be decreased just enough by the peak voltages in a voice-coil to cause subtle decreases in the excitation of this voice-coil, which is physically attached to the membrane that produces the audible sound. (Maybe this is one reason why ‘that sound’ is exclusive to AlNiCo magnet drivers.)

GENERAL DESCRIPTION

Our 288-8H (16H) is a large format [1.4 in. (36 mm) diameter throat exit] high frequency compression driver, featuring a 3.4 lbs. (1.54 kg) Alnico V magnet, which produces an [at-rest] gap flux density of 2.05 T. It also features a 2.8 in. (71 mm) diameter, edge-wound, copper/clad aluminum-ribbon voice-coil. The voice-coil is attached to a high grade aluminum alloy diaphragm. Sound waves from the high frequency voice-coil-diaphragm assembly are channeled through our Radial Waveguide phasing system. This system provides the proper phase relationship between the sound waves emanating from the center of the diaphragm assembly and the sound waves emanating from the edges of the diaphragm assembly. An exponential throat is utilized to pass these phase coherent sound waves through the body of the driver to its exit port.

We designed our 288-8H (16H) driver for coupling to any of the industry standard multi-cellular, sectorial, or constant-directivity horns that have a 1.4 in. (36 mm) diameter throat entrance. These horns can be secured to our 288-8H (16H) driver by either the three-bolt mounting standard [bolt centers on a 3.25 in. (83 mm) diameter] or the four-bolt mounting standard [bolt centers on a 4.75 in. (121 mm) diameter].

Great Plains Audio manufactures the voice-coil-diaphragm assembly used in the 288-8H (16H) and this assembly can still be replaced ‘in the field’ by untrained personnel, without the use of special tools. Adjustable dowel pins allow each diaphragm assembly to be precisely centered in the voice-coil gap.

Each member of our team at Great Plains Audio has over 20 years of experience in building high quality audio products. We employ our combined skills and expertise to manufacture the 288-8H (16H). Our design of this driver was based on the 288-8G, once acknowledged as the finest compression driver for high frequency sound reproduction.

SPECIFICATIONS

Frequency Response: 500 Hz - 15 kHz (see figure 1.)

Power Rating: 40 watts continuous band limited (500 Hz - 20 kHz) pink noise with a 6 dB crest factor according to AES Standard 2.

Sensitivity: 109 dB SPL from 1 watt input of band-limited pink noise 500 Hz to 3000 Hz, measured at 1 meter from mouth of Altec 311-90 horn.

Maximum Output: 120.5 dB SPL (at 1M, calculated from Sensitivity and Power Rating)

Nominal Impedance: 8 ohms (288-8H) or 16 ohms (288-16H)

Magnet Type: Alnico V

Magnet Weight: 3.4 lbs. (1.54 kg)

Flux Density: 20,500 Gauss

Throat Exit: 1.4-in. (36 mm) diameter

Voice Coil: 2.8 in. (71 mm) diameter

Input Connections: Spring-loaded push terminals

Horn Mounting: Three bolt standard [bolt centers on a 3.25 in. (83 mm) diameter]
Four bolt standard [bolt centers on a 4.75 in. (83 mm) diameter]

Crossover (Optional): N1200-8A, 1,200 Hz, 12 dB/ Octave, Passive LF and HF

Finish: Textured Black Powdercoat

Dimensions: 7.1 in. (180 mm) diameter; 5.1 in. (130 mm) height

Weight
Net: 21.4 lbs. (9.71 kg)
Shipping: 23 lbs. (10.43kg)

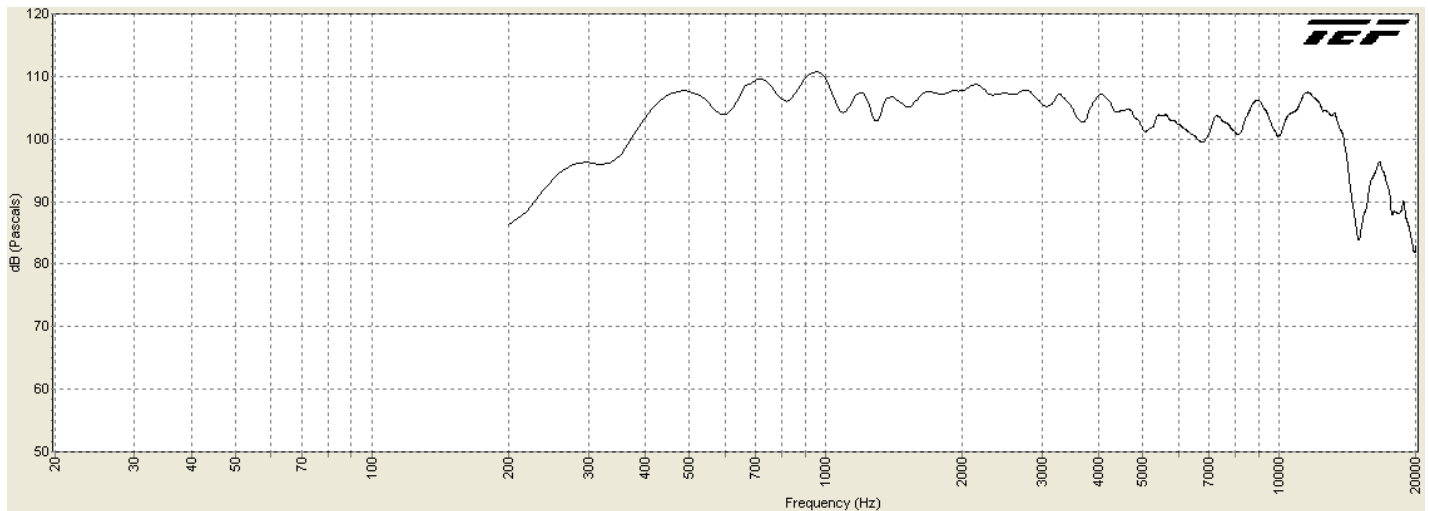

Figure 1.
(from 1 watt input, measured at 1 meter from exit of 311-90 horn)

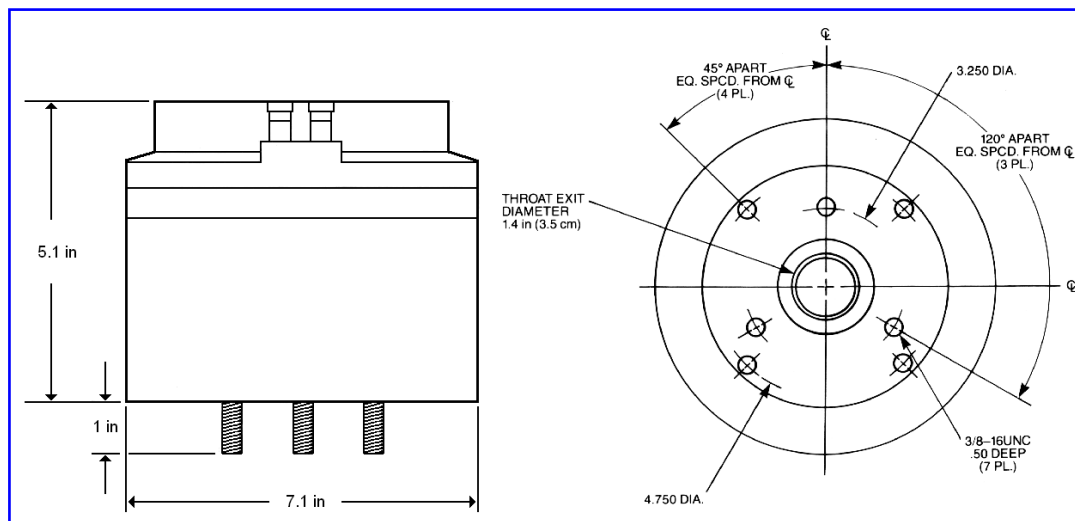

Figure 2.



Great Plains Audio
 7127 N.W. 3rd Street
 Oklahoma City, OK 73127
 405.789.0221

www.greatplainsaudio.com

"The Legacy Lives On"™

© Great Plains Audio LLC

Specifications subject to change without notice. Overall performance will maintained or improved